

Made for Motion



Cooling systems

For mobile machines and stationary hydraulics
Customised solutions or standard design

2023/24
www.ktr.com

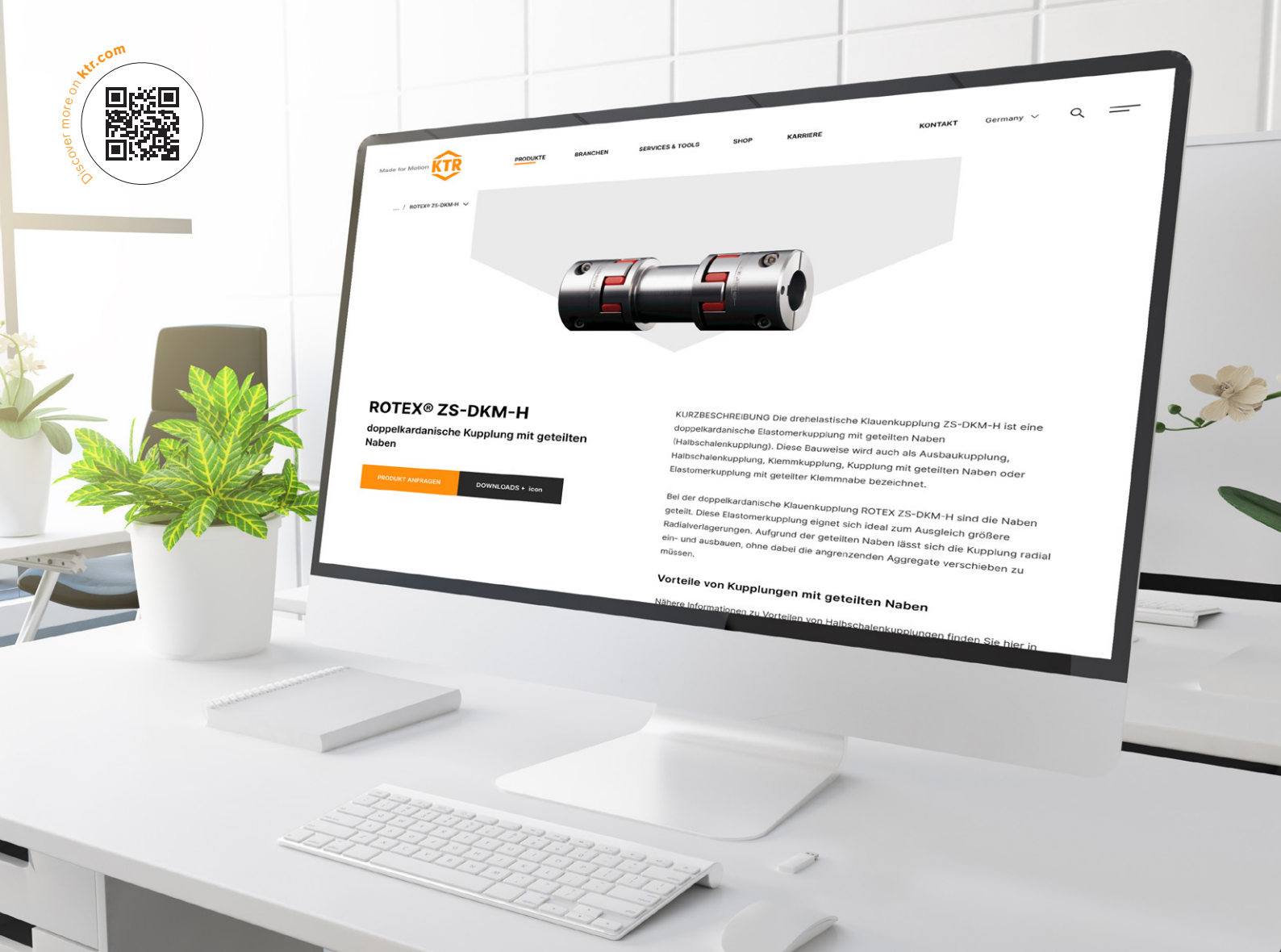

One for all and everybody

The new website will soon go online

There will be no alteration, no revision, nor merely a facelift: There will rather be a comprehensive relaunch of our website making our company, our products and our services digitally accessible in a more detailed and convenient way than ever before.

The conception stage of the relaunch project managed by Melanie Gunka and Julian Birich already started in September 2021. Initially numerous international specifications of requirements as well as in-house and external surveys were executed. The target was to provide only one digital platform for all in the future - accordingly for example integrate the platforms ktr360.com and ktr-events.com completely in the new website.

„The focus is definitely on improving the services and usability of the website for visitors“, Melanie Gunka underlines. „All contents are concentrated in one place and the performance is significantly increased. The objective is to raise the user experience to a new level.“ For that purpose a new, comfortable and quick search func-

tion is integrated, as an example. The streamlined structure as well as links to products and services facilitate navigation and consequently locating the numerous offers of KTR. Besides, its responsive design makes the new website equally easy to access for all terminal devices. The login area is significantly facilitated as well: In the future customers only have to log in once to have access to all contents and applications, from miscellaneous downloads and services to 3D-CAD drawings.

After launching both the KTR configuration tools are to be natively embedded in the website and all national versions of the website are to be adapted in the course of 2023 - to make sure all customers are able to benefit from the advantages of our retreated website in the respective national language step by step worldwide.

DID YOU KNOW ...

that couplings, brakes and hydraulic components are part of our scope of supply, too?
Details are available at ktr.com.

Made for Motion 



Drive Technology

- Couplings
- Torque limiters
- Clamping elements
- Torque measuring systems

www.ktr.com



Made for Motion 



Brake systems

- KTR-STOP®
- EMB-STOP
- SBT Systems

www.ktr.com



Made for Motion 



Hydraulic components

- Bellhousings
- Damping elements
- Cooling systems
- Oil tanks

www.ktr.com



POSSIBLE COMBINATIONS

Our cooling systems are available as a package with our drive components.

Perfect in Combination with our
COUPLINGS

Made for Motion 



Drive Technology

- Couplings
- Torque limiters
- Clamping elements
- Torque measuring systems

www.ktr.com

Those who value KTR as a manufacturer will love us as a partner.

KTR provides the mechanical and plant engineering with an extensive portfolio of high-quality drive and hydraulic components as well as braking and cooling systems. We are pleased to be at your service during the designing stage and develop tailor-made solutions for you. Perfectly organized logistics, global presence via 24 subsidiary companies and more than 90 distribution partners along with an international network consisting of 8 production sites are the prerequisite for quick delivery. When it comes to service we ensure short distances along with competent and personal support.

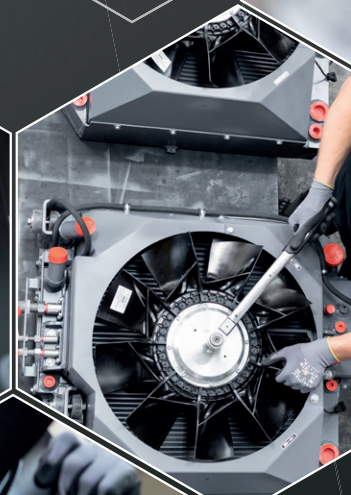



„Customised solutions – for every application.“

Franz-Josef Hoffmann, Engineered Business Cooling Systems

**Wherever motion is essential,
we have the right answer.**



Drive technology

Mechanical components are and will remain essential in drive technology. The industry's demands on components grow continuously: energy efficiency, power density, ease of servicing and electrification. Our portfolio includes couplings and torque limiters, clamping sets and universal joints as well as torque measuring shafts.

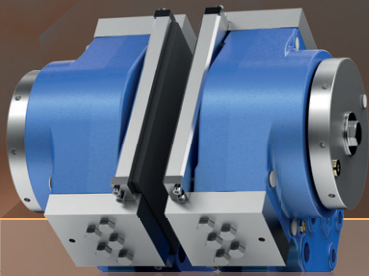

Brake systems

Our hydraulic and electromechanical brake systems are globally used in various industries. Customer preference and parameters of the application decide upon the selection of the right brake.

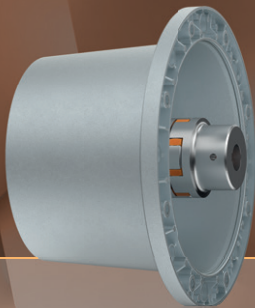

Hydraulic components

For almost 50 years we have provided the industry with a continuously growing range of hydraulic components from our in-house development and manufacturing: accurate selection, high-quality processing, quick availability.



Cooling systems

As a customised product or standard solution, multimediuim or oil/air cooler, for mobile machines or stationary hydraulics, optionally available as a marine or ATEX version, powerful and efficient.

OUR INDUSTRIES



Wind power



Construction and agricultural machines



Pumps and compressors



Indoor materials handling



Machine tools

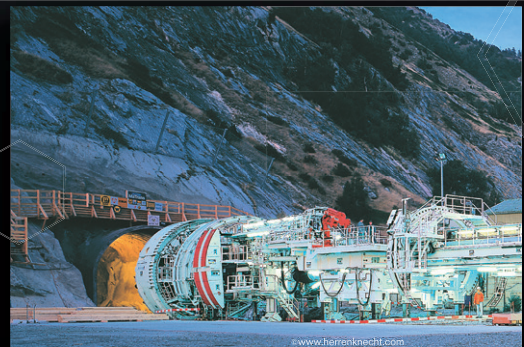

Hydraulics

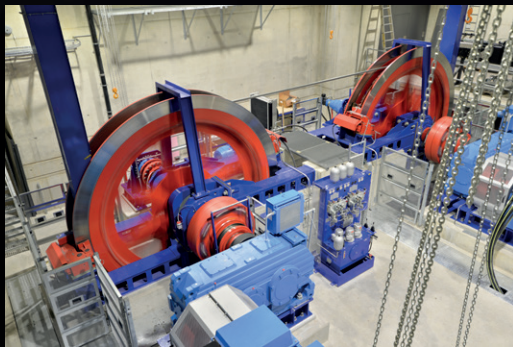

General drive technology



Marine / shipbuilding



Stationary power generation

SUMMARY OF PRODUCTS/INDUSTRIES

WIND POWER	Gearless wind turbines	Wind turbines	Local power grids	CONSTRUCTION AND AGRICULTURAL MACHINERY	Excavators	Road rollers	Crushers	Combine harvesters	Tank spreaders	PUMPS AND COMPRESSORS	Compressors	Pumps	Cooling towers	INDOOR MATERIALS HANDLING	Conveying and storage	Food processing machinery	Packaging machinery	Automation

Cooling systems																		
Cooling system type MMC																		
Combined coolers type MMC					■	■	■	■	■		■	■			■			■
Oil/air cooler type OAC																		
Cooling system type OAC	■	■	■									■						
Cooling system type OPC																		
Cooling system type OPC																		
Oil/water cooler																		
PHE											■							
TAK/TP											■							

Machine Tools	Positioning axes	Main spindle drives	Robotic drives	HYDRAULICS	Power pack production	Plastics processing industry	GENERAL DRIVE TECHNOLOGY	Industrial gears	Planetary gears	Extruders	Metering machines	Steel mills	Linear technology	SHIPBUILDING / MARINE	Cargo ships	Cruises	Yachts	Workboats	GENSETS	Emergency power generators	Product pages from page	
																						14
																						20
																						35
																						48
																						50





TABLE OF CONTENTS

KTR website relaunch / One for all and everybody	2
Company presentation	4
Product fields and overview of industries	6
Summary of products divided into industries	8
Customised Solutions – Benefits	12
Combined coolers type MMC	14
Oil/air cooler type OAC	15

Cooling systems MMC – Customised Solutions

System development	16
Structure	17
Manufacturing expertise	18
Applications	19

Cooling systems type OAC

Oil/air cooler	
Online tool for oil/air coolers	20
Cooling system type OAC	22
Type code	24
Technical data	25
Diagrammes of performance and pressure loss	26
Dimensions	29
Cooling system type OPC	35
Dimensions	36
Type code	40

Accessories

Oil/air cooler	
Cooler accessories thermal and pressure bypass	41
Cooler accessories control and converter	42
Oil thermostat valve OTV	43
Cooler accessories filter	44
Cooler accessories	45
Cooling system type PIK	46
Oil/water cooler	
Cooling system type PHE	48
Cooling system type TAK/TP	50
TAK/TP diagramme of cooling, performance and pressure loss	51
TAK/TP Series A-C	52
TAK/TP Series D-F	53
TAK/TP Diagrammes of performance	54

Summary of literature	58
-----------------------	----

MMC

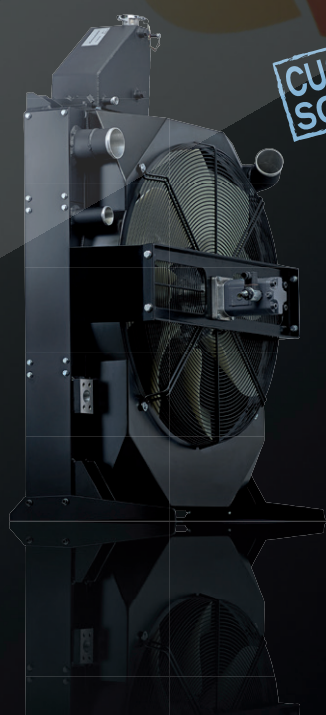

CUSTOMISED SOLUTIONS

OAC



STANDARD DESIGN



CUSTOMISED SOLUTIONS



Optimised delivery times, high delivery performance



Consistently high quality of products



Extensive know-how and portfolio per industry



Engineering, project management and personal advice



Tailor-made solutions: customised and application-specific



Combined coolers type MMC

Cooling systems

Overview of the MMC cooling system

Depending on the application features, our multiple-circuit coolers series MMC (Mobile Machinery Cooler) combine different media such as oil, water, fuel and air in one single cooling system. Main application ranges are engine cooling in agricultural and construction machinery, stationary I. C.-engines. Tailor-made coolers for hydraulic applications as well as cooling of compressors supplement the MMC portfolio. Every MMC cooler is a project-specific version that is calculated and developed by our engineers for the very special application.



MMC series

- customised design
- single-circuit and multiple-circuit coolers
- project-specific selection
- performance simulation for application-specific data generation
- cooling of motors, hydraulic oil and compressed air

CUSTOMISED SOLUTIONS

Other types

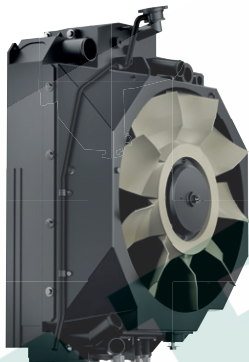

MMC motor system coolers



MMC hydraulic coolers

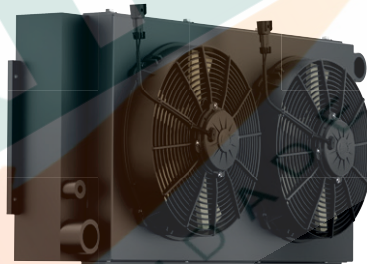

MMC compressor coolers

Applications



Construction machines



Diesel engines



Special hydraulics



Compressors

Oil/air cooler

Cooling systems

Overview of the OAC cooling system

The oil/air coolers type OAC and OPC are compact and high-performance coolers for cooling hydraulic, gear, lubricating and motor oils as well as water glycol. Main applications are hydraulic power packs, machine tools, hydraulic presses, wind power and rail technology as well as iron and steel industry. Besides marine and ATEX versions the coolers are available in combination with thermal or pressure bypass valves.



OAC series

- Defined portfolio of oil coolers
- Single-circuit coolers
- Performance-related product selection
- Recorded in catalogue tables

STANDARD DESIGN

Other types



OAC oil/air cooler
High-performance cooling for stationary hydraulics

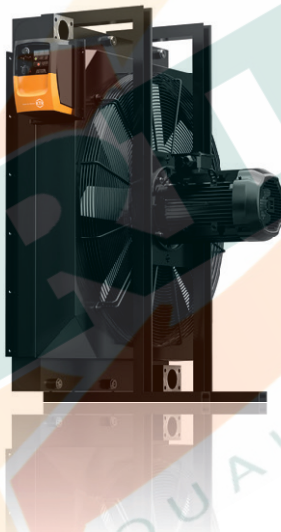

OAC oil/air cooler
Infinitely variable adaptation of cooling capacity based on requirements



OPC Oil/air coolers
Bypass flow cooling with integrated pump

Applications



Wind energy



Stationary hydraulics



Marine

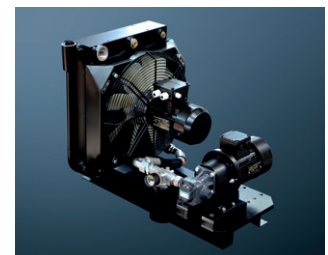

Gearbox

Combined coolers type MMC Cooling systems

Application-specific system development



- Every cooler is a unique copy
- Competent support throughout the entire development cycle: From development of ideas through simulation to series of prototypes, start-up and series production.
- Services by R + D: Visual inspection, pressure testing, pressure threshold testing, optimum pressure testing, initial sample inspection
- 24 subsidiary companies globally for supporting your projects locally

Measuring test bench, for determining actual performance data of specifically designed heat exchangers

- cooling water circuit
- cooling of charge air
- cooling of hydraulic and gear oil
- provides validation of performance data
- supports innovative developments
- optimises application-specific developments
- allows for transfer of know-how
- ...

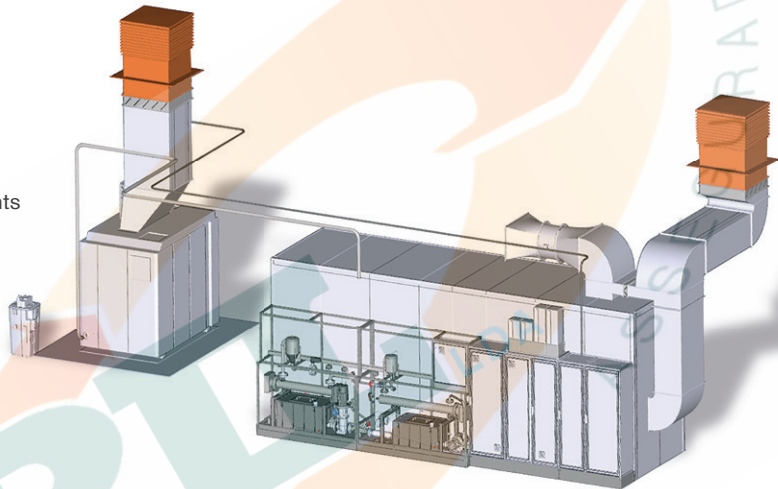

Selection

To determine an optimum cooling system for your individual application we count on our specifically programmed selection software. The data stored are not only based on wind tunnel measurements, but also on CFD simulations. The basis for the calculation is the determination and assessment of application-specific parameters and influence factors. Our engineers support the projects with know-how and experience to the finished product in your application.

Thermische Auslegung Made for Motion

Projektname: MMC-System Customized Maschinen&Hydraulik Kühlsystem

Projektnummer: MB523-112018

Kunde: Fahrzeugbau GmbH Kundennummer:

Datum: 2018-11-01 Autor: F.-J. Hoffmann Ersteller:

Eingangsdaten

Lernfunktionskombination: 30KC3002-958R2502-113 (Wasser/Öl-Luft-Kühler)

Länge der Rohre: 532 [mm] Breite: 410 [mm]

Fluid innen (Einlass): Fluid außen (Einlass):

Fluid: ISO VG 46 Fluid: Air

Temperatur: 82,4 [°C]	Temperatur: 48 [°C]
Druck: 2500 [hPa]	Druck: 1013,15 [hPa]
Durchsatz: 150 [l/min]	Durchsatz: 5,3 [m³/s]

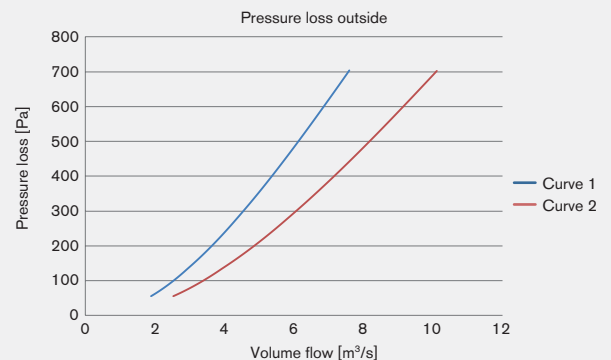
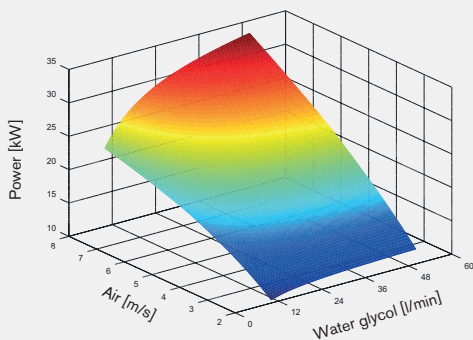
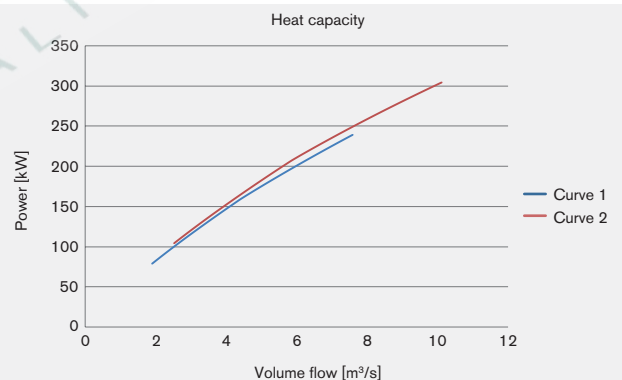

Combined coolers type MMC

Cooling systems

Structure

The MMC cooler is a high-performance cooler made of aluminium. It combines several cooling circuits, for example for charge air, water and oil in one single system. The design of the cooler is specifically suitable for heavy duty applications. The laminae are selected based on thermal and hydraulic parameters. The depth of the cooler cores may vary between 32 mm and 200 mm. The cooler dimensions are specifically adapted to the respective mounting space. Here sizes up to 2000 mm are feasible. The selection of the fan is based on the requirements calculated such as mass flow, noise generation, speeds, etc. When designing the drive there is the option to select between a direct fan drive, an electric motor adapted to the operating parameters or a hydro motor.



Laminae structure

The core of our cooling systems as a proven plate and bar technology. The different shapes of the laminae structures allow for an infinite variety of types which are accurately selected and tailored for your application.

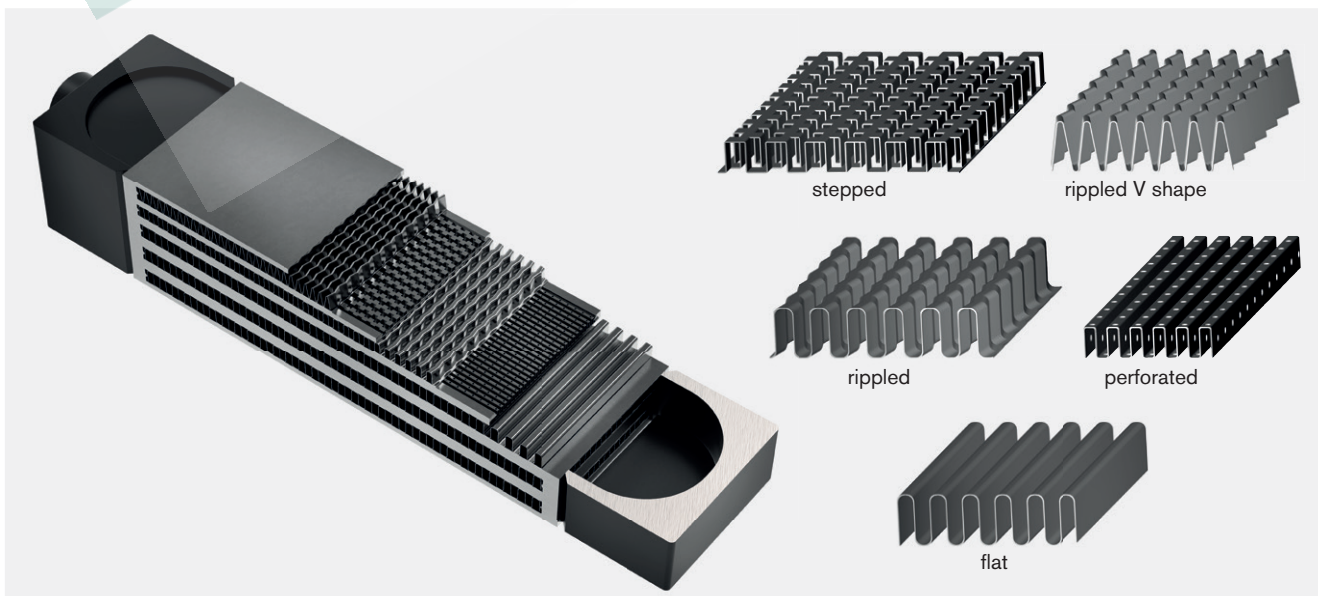

Combined coolers type MMC

Cooling systems

Manufacturing expertise in our own plant



Our new cooler production plant in Jiaxing located 100 kilometers southwest of Shanghai commenced operations at the end of 2018. On an effective area of about 9,000 m² we manufacture high-quality cooling systems for the global market being used as multimediuim coolers in construction and agricultural machinery or as oil/air coolers in stationary hydraulics.

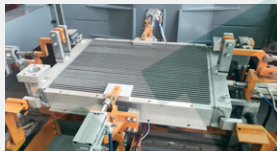

For that purpose we invested in a state-of-the-art machinery park. Joachim Grunwald, Product Manager of MMC combined coolers: „We are in a position to manufacture smaller quantities with a high level of automation and consequently at a constantly high quality level here.“ There is a very close cooperation between the manufacturing specialists in Jiaxing and the design engineers and project managers in Rheine. Since the team of engineers at KTR's headquarters in Rheine/ Germany is and remains responsible for the development of the cooling systems.



Customers' benefits at a glance

- **Higher capacity**
Availability ensured by the expansion of production capacity.
- **Optimised delivery times**
Customised delivery times by individual production planning and capacity.
- **Optimised access to quality**
State-of-the-art production lines, robotic welding systems and our qualified staff ensure a high level of quality.
- **Future-oriented engineering**
Due to the combination of project management, development, designing and production we bring together all process steps in one location.

Combined coolers type MMC

Cooling systems

Various applications



Examples of references



Weycor wheel loader AR530 by Atlas Weyhausen

The wheel loader is one of the medium size types of the portfolio equipped with a water-cooled 4-cylinder DEUTZ engine series TCD 3.6 L4 High Torque with a 3.6 litres displacement and a maximum power of 55 kW.

KTR was commissioned with the selection of the cooling system. For cooling charge air, cooling water and hydraulics a triple-circuit combined cooler type MMC is used.

Open Power Unit by Hatz

The diesel engine manufacturer located in Lower Bavaria provides all variants of the new H series as a pre-finished open power unit. The standard model, the water-cooled 4-cylinder 4H50TIC with 2 litres displacement and a maximum power of 55 kW counts on common rail technology, turbo loader and external exhaust gas recirculation.

For cooling charge air and engine cooling water a dual-circuit combined cooler type MMC by KTR which was dimensioned in cooperation with Hatz is used. In addition the scope of delivery comprises a compact oil cooler installed at the engine side cooling the engine oil via the engine cooling water.



Online tool for oil/air coolers type OAC

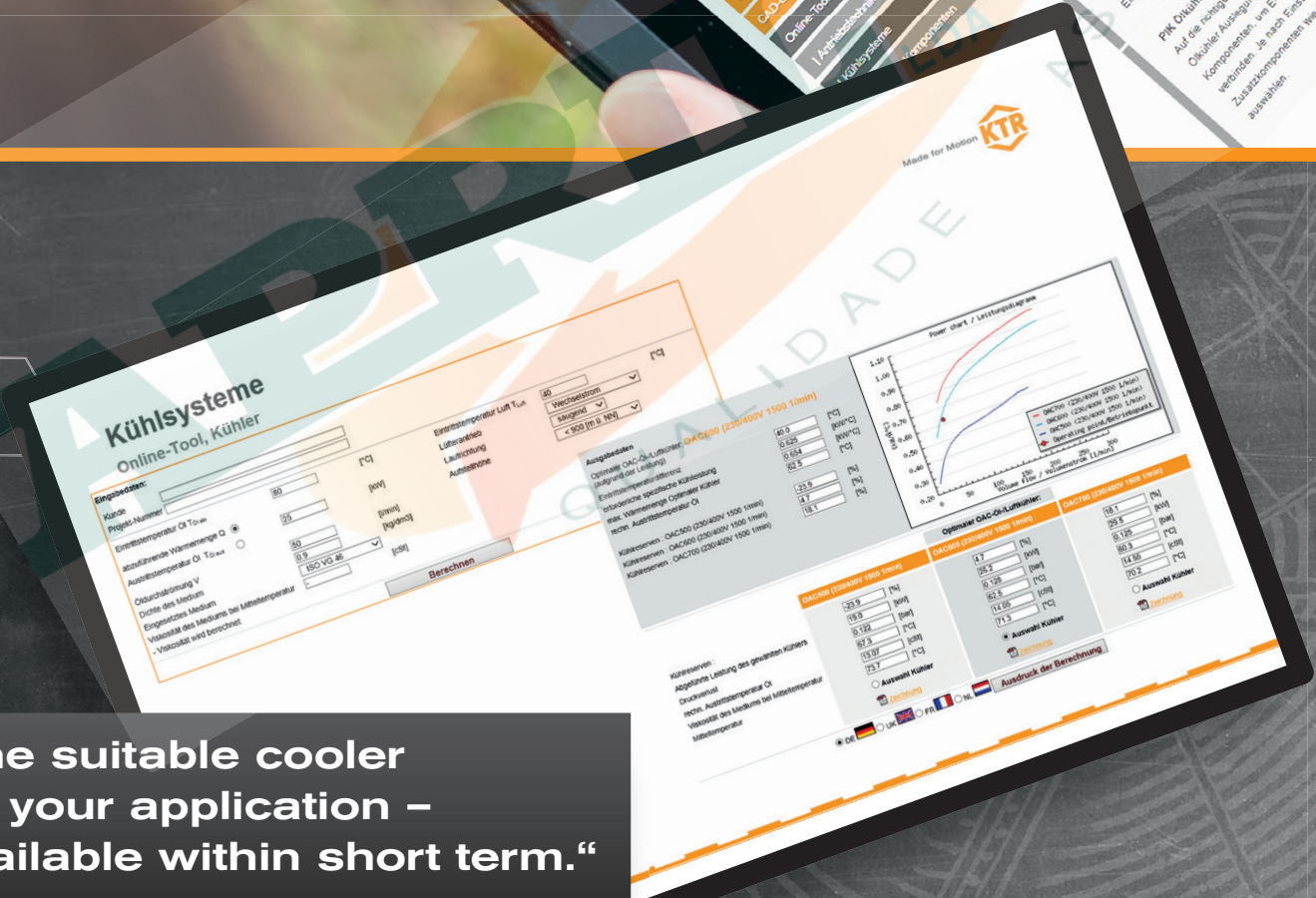

„The suitable cooler for your application – available within short term.“

Christoph Bettmer, Core Business Hydraulics/Product Manager

STANDARD DESIGN



Hydraulik-Komponenten
Pumpenaggregate und Zubehör
Schalter und Zubehör
Temperaturmessung und -überwachung
Kühlstationen
Kühler

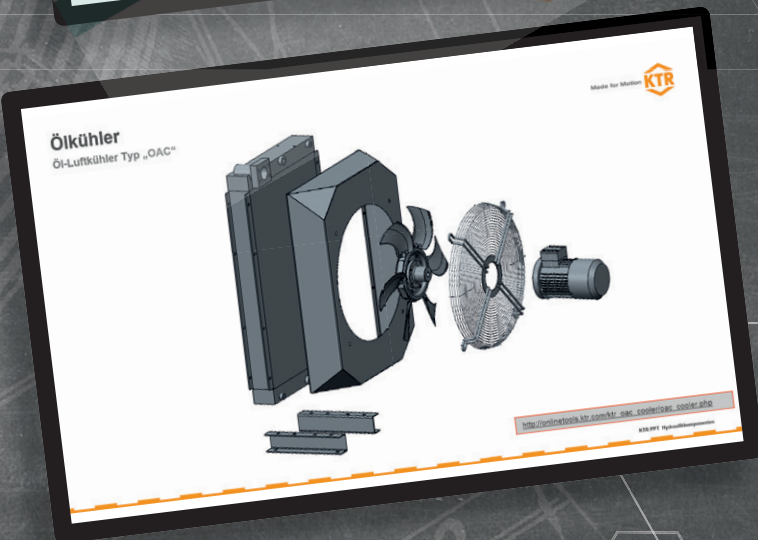

Exclusively for OAC oil/air coolers.

Our online tool makes selecting easy for you: Based on the data you enter such as ambient and oil temperatures, installation height and requested fan drive the tool calculates the suitable cooler promptly.

Apart from that you are provided with clear data processing and a descriptive 3D model as well as a link to our online shop.

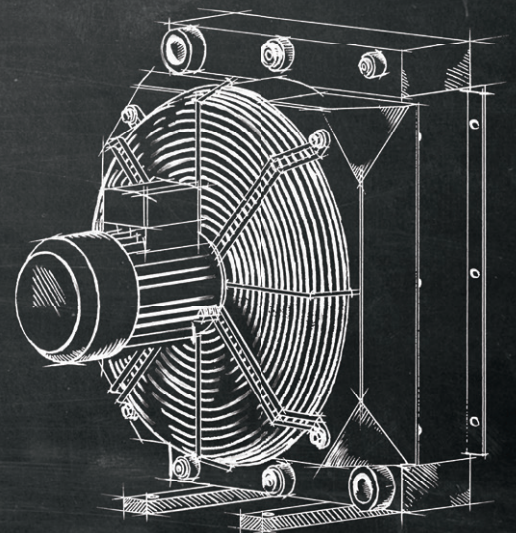

tools.ktr.com

Oil/air cooler type OAC

Cooling systems

High-performance cooling of hydraulic and lubricating oils



A compact and high-performance cooler series comprising twelve sizes was developed for high-performance cooling of hydraulic and lubricating oils.

Applications:

- Construction machines
- Agricultural machines
- Rail technology
- Machine tools
- Hydraulic power packs
- Wind power
- Hydraulic presses
- Iron and steel industry etc.

Applicable for cooling of:

- Hydraulic oil
- Gear oil
- Lubricating oil
- Water glycol (min. 40 % glycol)

Structure:

- Cooler core (plate and bar) made of aluminium with industrial laminae in black (RAL 9005)
- Fan cover made of steel in black (RAL 9005)
- Fan made of nylon PAG
- Protective grid made of steel in black (RAL 9005)
- Fan 12/24V IP68, 230/400V, 400/690V, IP55
- Fan with hydraulic drive

Marine design:

- Cooler core, frame, fan cover with double-component paint
- Electric motor with special paint and protection class IP56

ATEX design:

- Gas sector: Ex II 2G Ex h IIC T6...T3 Gb X
- Dust sector: Ex II 3D Ex h IIIC T68 °C...110 °C Gb X
- Ambient temperature $-40\text{ °C} < T_a < +55\text{ °C}$
- Motor and fan as an adequate ATEX design

Accessories (see page 51 et seqq.):

- Thermal bypass valves
- Oil thermostat valve (OTV)
- Protective grid
- Temperature switch (TSC)
- Speed-controlled operation

The OAC coolers have to be protected from direct solar radiation.

Selection system

To select the suitable cooler you need to know the following details:

Q [kW]	Heat to be dissipated
V [l/min]	Oil flow
T _{oil} [°C]	Inlet temperature of oil into cooler
T _L [°C]	Inlet temperature of ambient air into cooler

Example of calculation

Details given:

Q = 12 kW
V = 75 l/min
T _{oil} = 65 °C
T _L = 30 °C

Performance diagramme of OAC400

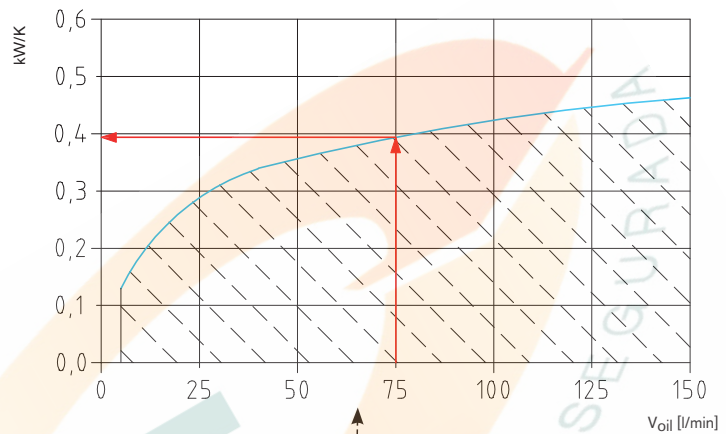

Calculation of specific cooling capacity

Difference of inlet temperature ETD [°C] = T_{oil} - T_L

Specific cooling capacity required P_{requ.} = Q/ETD

The specific cooling capacity required must fall below the performance curve! → 12 kW/(65 °C - 30 °C) = 0.34 kW/°C

The following was selected: OAC400

The actual cooling capacity of the cooler is 0.39 kW/°C x 35 °C = 13.65 kW

Calculation of pressure loss

The pressure loss in the curves of the different data sheets is based on a viscosity of 30 cSt.

The effective pressure loss is calculated as follows:

Pressure loss (from curve) x factor = effective pressure loss

Example

V _{oil} : 75 l/min
Viscosity: 20 cSt

→ 0.31 bar x 0.75 = 0.233 bar

Pressure loss 30 cSt

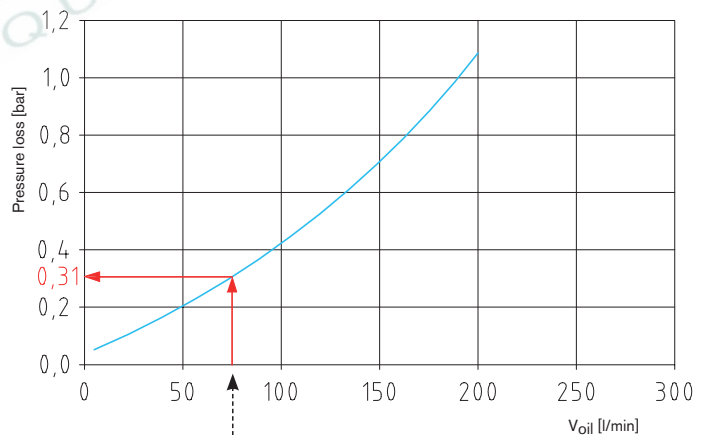

Conversion factor of pressure loss

cSt	10	15	20	30	40	50	60	80	100
Factor	0.5	0.65	0.75	1	1.2	1.4	1.6	2.1	2.8

Oil/air cooler type OAC

Cooling systems

Type code of industrial cooler oil/air

OAC - **200** - **M** - **03** - **B** - **4** - **A** - **0** - **0**

Size of cooler	Type	Engine	Effective direction	Number of poles or displacement	Voltage	Bypass	Protective grid against stones
100	No specification = Standard	00 = Without engine	Standard = Sucking (no specification required)	0 = Not applicable	To be omitted if not applicable	0 = Without bypass	0 = No
200		01 = Direct current 12V		2 = Number of poles			
250		M = Marine (seawater resistance)	02 = Direct current 24V	B = Pressing	4 = Number of poles	A = 230/400V 50 Hz 460V 60 Hz	TB6 = Thermal bypass (6 bars/50 °C)
300	03 = AC current		6 = Number of poles		B = 400/690V 50 Hz		
400	ExG = ATEX (gas-protected area)	04 = Hydraulics		8 = Number of poles	C = 230V 50/60 Hz (single-phase)	DB6 = Pressure bypass (2, 4, 6 bars)	
500		09 = Special		6 = Displacement			D = 230/400V 50/60 Hz Compact fan (OAC300/400)
600	ExD = ATEX (dust-protected area)			8 = Displacement	Z = Special voltage*	DB4F = Pressure bypass (4 bars)	
700				11 = Displacement			* Special voltage in plain language
800	M-ExG = Marine & ATEX (gas)			14 = Displacement			
850				19 = Displacement			
900	M-ExD = Marine & ATEX (dust)						
1000							
2000	ECO2 = Speed-controlled operation						

Oil/air cooler type OAC

Cooling systems

Technical data

12V and 24V fan drive										
Type of cooler ³⁾	Voltage [V]	Drive [kW]	Speed [rpm]	Amperage [A]	Protection class	Fan Ø [mm]	Perm. pressure [bar]		Max. volume flow [l/min]	Weight [kg]
							Static	Dynamic		
OAC100-01	12	0.09	3950	7.2	IP68	190			50	6
OAC100-02	24	0.06	3625	2.6	IP68	190			50	6
OAC200-01	12	0.10	2838	8.2	IP68	280			100	11
OAC200-02	24	0.11	2925	4.4	IP68	280			100	11
OAC250-01	12	0.10	2838	8.2	IP68	280			120	13
OAC250-02	24	0.11	2925	4.4	IP68	280			120	13
OAC300-01	12	0.22	3080	18.4	IP68	350			120	16
OAC300-02	24	0.23	2730	9.4	IP68	350			120	16
OAC400-01	12	0.22	3080	18.4	IP68	350	26	14	200	22
OAC400-02	24	0.23	2730	9.4	IP68	350			200	22
OAC500-01	12	0.24	2600	20.2	IP68	385			200	30
OAC500-02	24	0.24	2700	9.8	IP68	385			200	30
OAC600-01	12	2 x 0.10	2838	2 x 8.2	IP68	280			250	43
OAC600-02	24	2 x 0.11	2925	2 x 4.4	IP68	280			250	43
OAC700-01	12	2 x 0.24	2600	2 x 20.2	IP68	385			250	53
OAC700-02	24	2 x 0.24	2700	2 x 9.8	IP68	385			250	53
OAC800-01	12	2 x 0.24	2600	2 x 20.2	IP68	385			350	81
OAC800-02	24	2 x 0.24	2700	2 x 9.8	IP68	385			350	81

³⁾ Max. medium temperature: 110 °C (higher temperatures on request)/Max. ambient temperature: 60 °C

Other motors on request

230/400V with 50 Hz; 460V with 60 Hz fan drive														
Type of cooler ²⁾	Driving power [kW]		Speed [rpm]		Amperage [A]		Protection class		Fan Ø [mm]	Noise ¹⁾ [dB(A)]	Perm. pressure [bar]		Max. volume flow [l/min]	Weight [kg]
	50 Hz	60 Hz	50 Hz	60 Hz	50 Hz	60 Hz	Standard	Marine			Static	Dynamic		
OAC100-03 C	0.07	0.08	2500	2700	0.29	0.33	IP54	-	200	64			50	16
OAC200-03 C	0.12	0.16	2450	2650	0.55	0.72	IP54	-	250	69			100	16
OAC200-03	0.18	0.21	1350	1650	0.58	0.57	IP55	IP56	280	66			100	16
OAC250-03	0.18	0.21	1350	1650	0.58	0.57	IP55	IP56	280	66			120	20
OAC300-03-4	0.37	0.43	1370	1670	1.04	1.02	IP55	IP56	380	76			160	24
OAC300-03-6	0.18	0.21	850	1020	0.87	0.88	IP55	IP56	380	63			160	24
OAC300-03 D	0.14	0.17	1400	1600	0.35	0.32	IP44	-	350	72			160	21
OAC400-03-4	0.37	0.43	1370	1670	1.04	1.02	IP55	IP56	380	76	26	14	200	29
OAC400-03-6	0.18	0.21	850	1020	0.87	0.88	IP55	IP56	380	63			200	29
OAC400-03 D	0.14	0.17	1400	1600	0.35	0.32	IP44	-	350	72			200	26
OAC500-03-4	0.37	0.43	1370	1670	1.04	1.02	IP55	IP56	380	78			200	37
OAC500-03-6	0.18	0.21	850	1020	0.87	0.88	IP55	IP56	380	63			200	37
OAC600-03	0.75	0.86	1440	1740	1.79	1.72	IP55	IP56	520	78			250	57
OAC700-03	0.75	0.86	1440	1740	1.79	1.72	IP55	IP56	520	78			350	70
OAC800-03	1.5	1.75	1435	1730	3.3	3.3	IP55	IP56	630	78			350	97
OAC850-03	2.2	2.55	965	1165	5.2	4.75	IP55	IP56	750	79			350	130
OAC900-03-6	2.2	-	965	-	5.2	-	IP55	IP56	900	85			450	173
OAC900-03-4	7.5	-	1465	-	14.3	-	IP55	IP56	900	97			450	205
OAC1000-03-8	1.5	-	700	-	4.65	-	IP55	IP56	900	81			530	154
OAC1000-03-6	2.2	-	965	-	5.2	-	IP55	IP56	900	87	21	14	530	187
OAC1000-03-4	7.5	-	1465	-	14.3	-	IP55	IP56	900	97			530	212
OAC2000-03-8	4	-	720	-	10.9	-	IP55	IP56	1000	86			700	329
OAC2000-03-6	7.5	-	980	-	16	-	IP55	IP56	1000	92			700	357
OAC2000-03-4	18.5	-	1470	-	35	-	IP55	IP56	1000	100			700	429

¹⁾ Measurement based on 50 Hz operation

²⁾ Max. medium temperature: 110 °C (higher temperatures on request)/Max. ambient temperature: 40 °C

Hydraulic fan drive										
Type of cooler ³⁾	Displacement [cm]	Speed [rpm]	Fan Ø [mm]	Noise [dB(A)]	Perm. pressure [bar]		Max. volume flow [l/min]	Weight [kg]	Volume flow [l/min]	Pressure [bar]
					Static	Dynamic				
OAC200-04-06	6.3		280	66			100	15	10	4
OAC250-04-06	6.3		280	66				15	10	4
OAC300-04-06	6.3		380	75				21	10	18
OAC300-04-08	7.9		380	75			160	21	13	15
OAC400-04-06	6.3		380	74				25	10	18
OAC400-04-08	7.9		380	74			200	25	13	15
OAC500-04-06	6.3	1500	380	74		26	200	34	10	18
OAC500-04-08	7.9		380	74				34	13	15
OAC600-04-08	7.9		520	78				50	13	27
OAC600-04-11	10.9		520	78			250	50	20	17
OAC700-04-08	7.9		520	78				60	13	27
OAC700-04-11	10.9		520	78			250	60	20	17
OAC800-04-11	10.9		630	78				88	18	34
OAC800-04-14	13.9		630	78			350	88	22	27
OAC850-04-14	13.9		750	79				110	15	45
OAC900-04-19	18.8	1000	900	85				155	20	82
OAC900-04-19	18.8	1500	900	95				155	46	132
OAC1000-04-19	18.8	1000	900	85	21	14		188	20	82
OAC1000-04-19	18.8	1500	900	97			530	188	46	132
OAC2000-04-44	44.1	1000	1000	92				295	48	87
OAC2000-04-44	44.1	1500	1000	100			700	295	107	126

³⁾ Max. medium temperature: 110 °C (higher temperatures on request)/Max. ambient temperature: 60 °C

Other motors on request

Oil/air cooler type OAC

Cooling systems

Diagrammes of performance and pressure loss

Performance diagramme



Diagramme of pressure loss



Conversion factor of pressure loss									
cSt	10	15	20	30	40	50	60	80	100
Factor	0.5	0.65	0.75	1	1.2	1.4	1.6	2.1	2.8

Performance diagramme

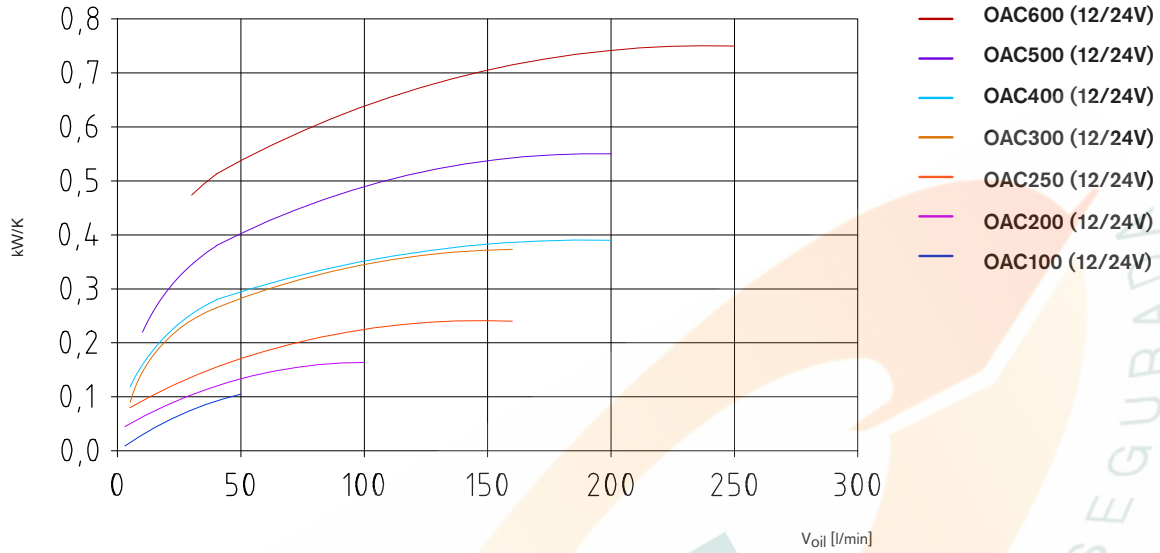
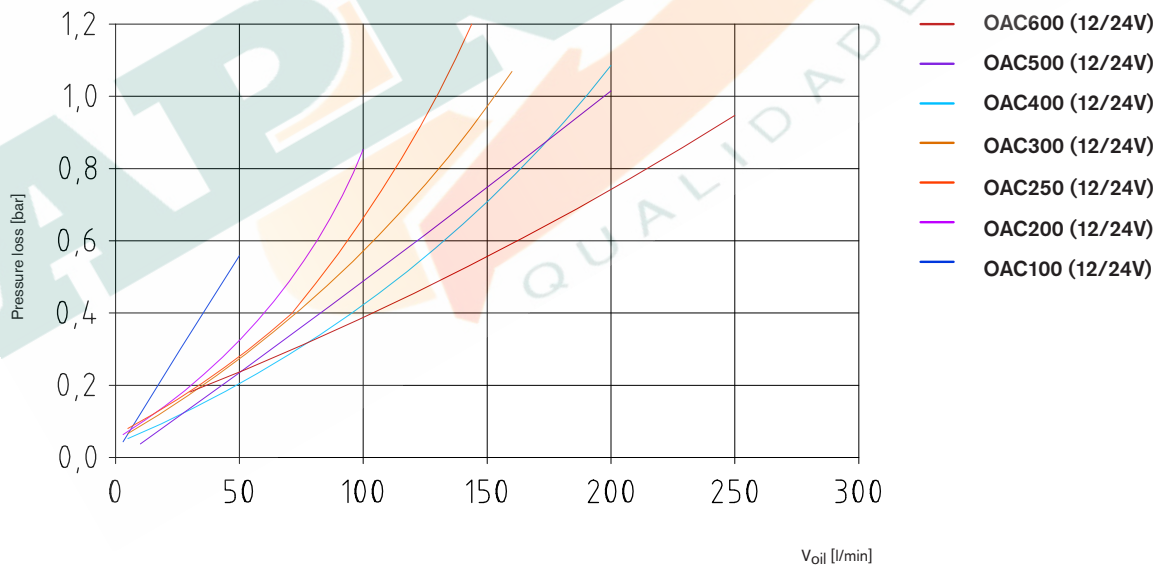

Diagramme of pressure loss



Conversion factor of pressure loss									
cSt	10	15	20	30	40	50	60	80	100
Factor	0.5	0.65	0.75	1	1.2	1.4	1.6	2.1	2.8

Oil/air cooler type OAC

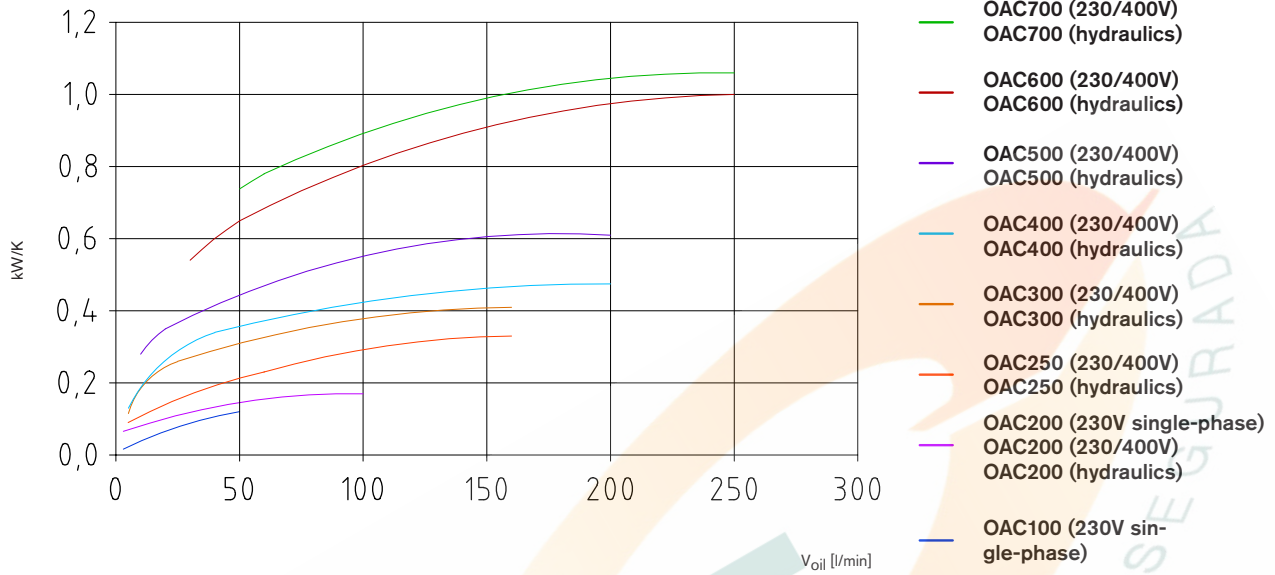
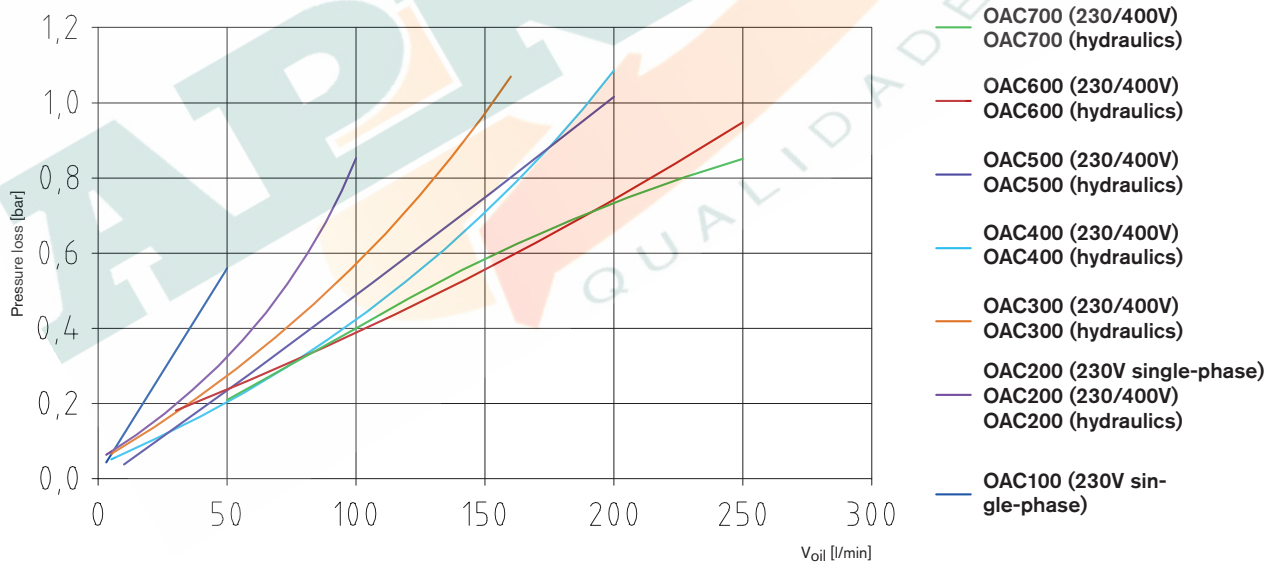
Cooling systems

Diagrammes of performance and pressure loss

Performance diagramme



Diagramme of pressure loss



Conversion factor of pressure loss									
cSt	10	15	20	30	40	50	60	80	100
Factor	0.5	0.65	0.75	1	1.2	1.4	1.6	2.1	2.8

Oil/air cooler type OAC Cooling systems

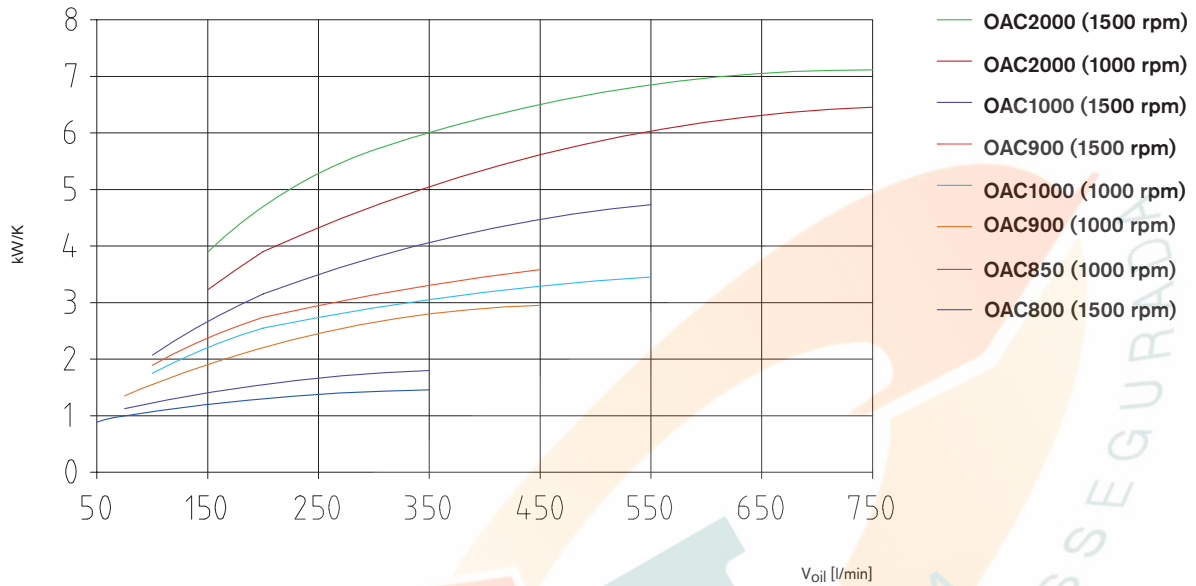
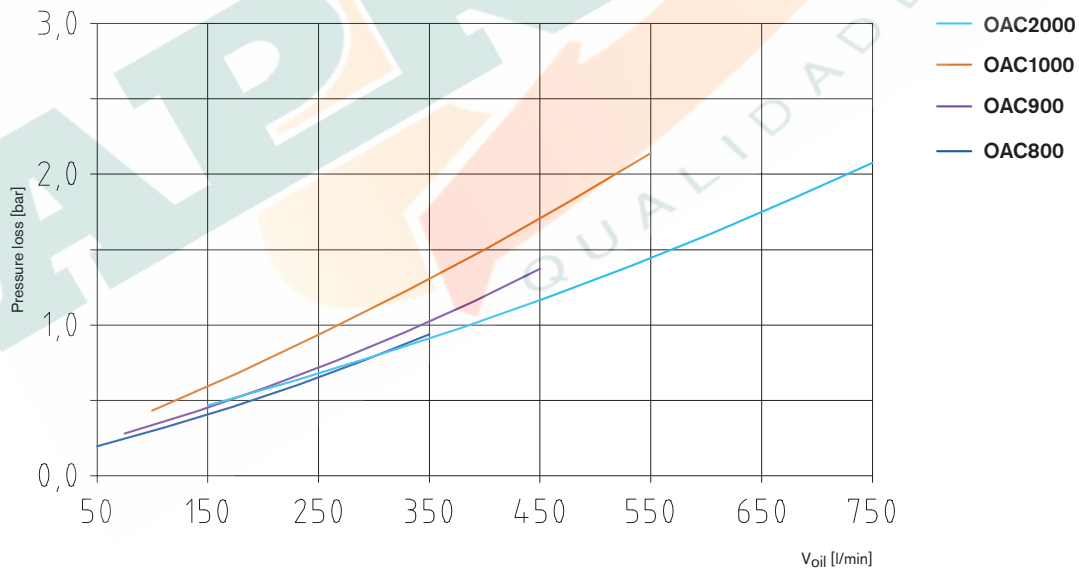
Dimensions of OAC100 - 800 (12/24V)

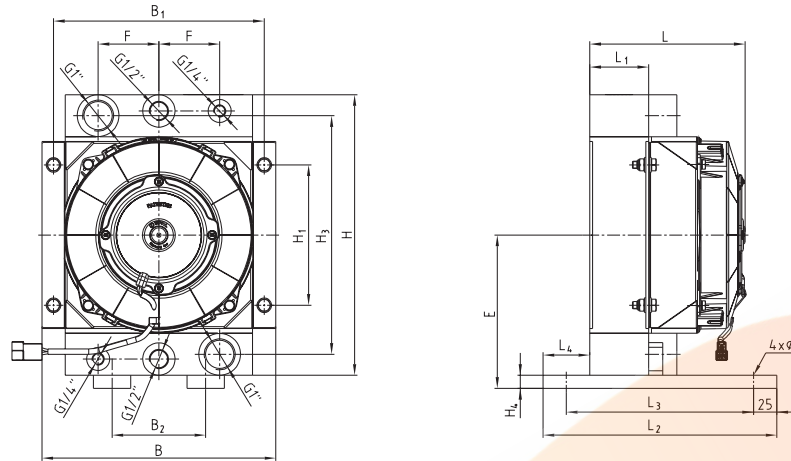

OAC100 - OAC400 12/24V

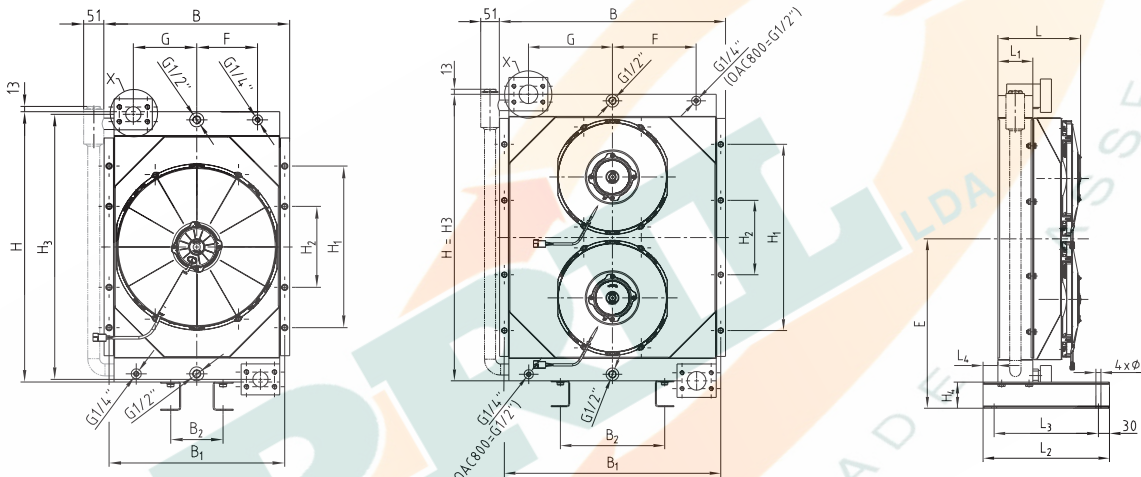

OAC500 12/24V

OAC600 - OAC800 12/24V

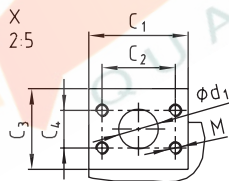

Oil/air cooler type OAC 12/24V																												
Type of cooler	Dimensions [mm]																			SAE flange	M	F	G	E				
	L	L ₁	L ₂	L ₃	L ₄	B	B ₁	B ₂	H	H ₁	H ₂	H ₃	H ₄	H ₅	d	d ₁	C ₁	C ₂	C ₃						C ₄			
OAC100-01	167	64	250	200	50	250	225	100	300	150	-	255	14	-	14	-	-	-	-	-	-	-	-	-	-	75	-	164
OAC100-02	167	64	250	200	50	350	325	174	410	240	-	360	14	-	14	-	-	-	-	-	-	-	-	-	-	115	-	219
OAC200-01	167	64	250	200	50	350	325	174	410	240	-	360	14	-	14	-	-	-	-	-	-	-	-	-	-	115	-	219
OAC200-02	197	95	250	200	50	350	325	174	410	240	-	360	14	-	14	-	-	-	-	-	-	-	-	-	-	115	-	219
OAC250-01	230	65	250	200	49	446	421	200	500	320	-	450	14	-	14	-	-	-	-	-	-	-	-	-	-	160	-	264
OAC250-02	230	65	250	200	49	446	421	200	500	320	-	450	14	-	14	-	-	-	-	-	-	-	-	-	-	160	-	264
OAC300-01	260	94	280	230	55.5	446	421	200	500	320	-	450	14	-	14	-	-	-	-	-	-	-	-	-	-	160	-	264
OAC300-02	260	94	280	230	55.5	446	421	200	500	320	-	450	14	-	14	-	-	-	-	-	-	-	-	-	-	160	-	264
OAC400-01	259	94	340	280	40	460	435	130	670	400	200	657	70	-	13.5	38	95	69.9	77	35.7	1 1/2"	M12	150	157.5	405	-	-	-
OAC400-02	259	94	340	280	40	460	435	130	670	400	200	657	70	-	13.5	38	95	69.9	77	35.7	1 1/2"	M12	150	157.5	405	-	-	-
OAC500-01	223	94	340	280	40	607	582	280	770	500	200	770	70	-	13.5	51	105	77.8	90	42.9	2"	M12	225	226	455	-	-	-
OAC500-02	223	94	340	280	40	607	582	280	770	500	200	770	70	-	13.5	51	105	77.8	90	42.9	2"	M12	225	226	455	-	-	-
OAC600-01	242	94	340	280	40	607	582	280	920	700	300	920	70	-	13.5	51	105	77.8	90	42.9	2"	M12	225	226	530	-	-	-
OAC600-02	242	94	340	280	40	607	582	280	920	700	300	920	70	-	13.5	51	105	77.8	90	42.9	2"	M12	225	226	530	-	-	-
OAC700-01	388	140	450	390	40	701	676	280	920	700	300	920	70	-	13.5	51	105	77.8	90	42.9	2"	M12	272	273	530	-	-	-
OAC700-02	388	140	450	390	40	701	676	280	920	700	300	920	70	-	13.5	51	105	77.8	90	42.9	2"	M12	272	273	530	-	-	-
OAC800-01	388	140	450	390	40	701	676	280	920	700	300	920	70	-	13.5	51	105	77.8	90	42.9	2"	M12	272	273	530	-	-	-
OAC800-02	388	140	450	390	40	701	676	280	920	700	300	920	70	-	13.5	51	105	77.8	90	42.9	2"	M12	272	273	530	-	-	-

Oil/air cooler type OAC

Cooling systems

Dimensions of OAC 300 - 800 (12/24V) speed controlled

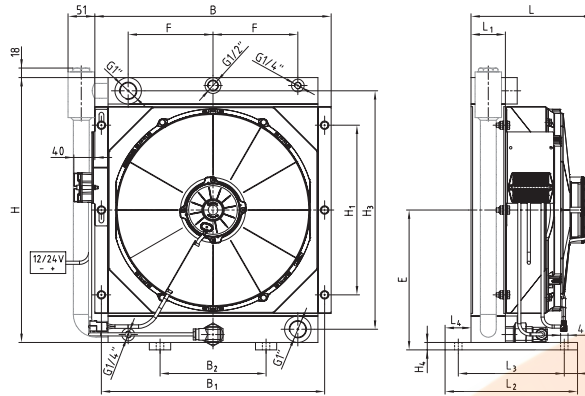

OAC300 - 400 12/24V

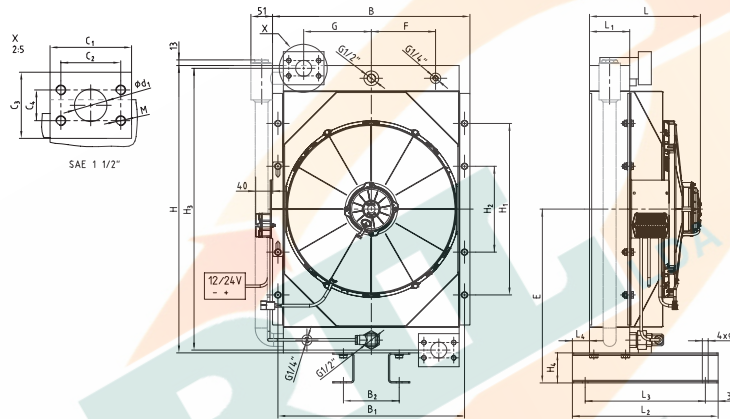

OAC500 12/24V

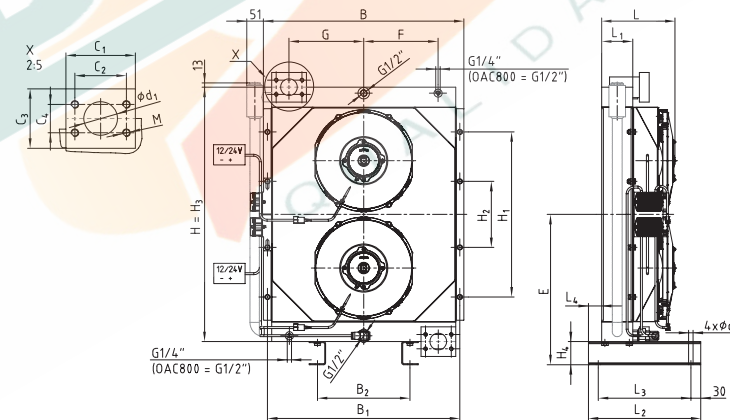

OAC600 - 800 12/24V

Oil/air cooler type OAC 12/24V speed controlled

Type of cooler	Dimensions [mm]																									
	L	L ₁	L ₂	L ₃	L ₄	B	B ₁	B ₂	H	H ₁	H ₂	H ₃	H ₄	H ₅	d	d ₁	C ₁	C ₂	C ₃	C ₄	SAE flange	M	F	G	E	
OAC300-01	230	65	250	200	49	446	421	200	500	320	-	450	14	-	14	-	-	-	-	-	-	-	-	160	-	264
OAC300-02	230	65	250	200	49	446	421	200	500	320	-	450	14	-	14	-	-	-	-	-	-	-	-	160	-	264
OAC400-01	260	94	280	230	55.5	446	421	200	500	320	-	450	14	-	14	-	-	-	-	-	-	-	-	160	-	264
OAC400-02	260	94	280	230	55.5	446	421	200	500	320	-	450	14	-	14	-	-	-	-	-	-	-	-	160	-	264
OAC500-01	259	94	340	280	40	460	435	130	670	400	200	657	70	-	13.5	38	95	69.9	77	35.7	1 1/2"	M12	150	157.5	405	
OAC500-02	259	94	340	280	40	460	435	130	670	400	200	657	70	-	13.5	38	95	69.9	77	35.7	1 1/2"	M12	150	157.5	405	
OAC600-01	223	94	340	280	40	607	582	280	770	500	200	770	70	-	13.5	51	105	77.8	90	42.9	2"	M12	225	226	455	
OAC600-02	223	94	340	280	40	607	582	280	770	500	200	770	70	-	13.5	51	105	77.8	90	42.9	2"	M12	225	226	455	
OAC700-01	242	94	340	280	40	607	582	280	920	700	300	920	70	-	13.5	51	105	77.8	90	42.9	2"	M12	225	226	530	
OAC700-02	242	94	340	280	40	607	582	280	920	700	300	920	70	-	13.5	51	105	77.8	90	42.9	2"	M12	225	226	530	
OAC800-01	388	140	450	390	40	701	676	280	920	700	300	920	70	-	13.5	51	105	77.8	90	42.9	2"	M12	272	273	530	
OAC800-02	388	140	450	390	40	701	676	280	920	700	300	920	70	-	13.5	51	105	77.8	90	42.9	2"	M12	272	273	530	

Oil/air cooler type OAC Cooling systems

Dimensions of OAC100 - 400 (230/400V)

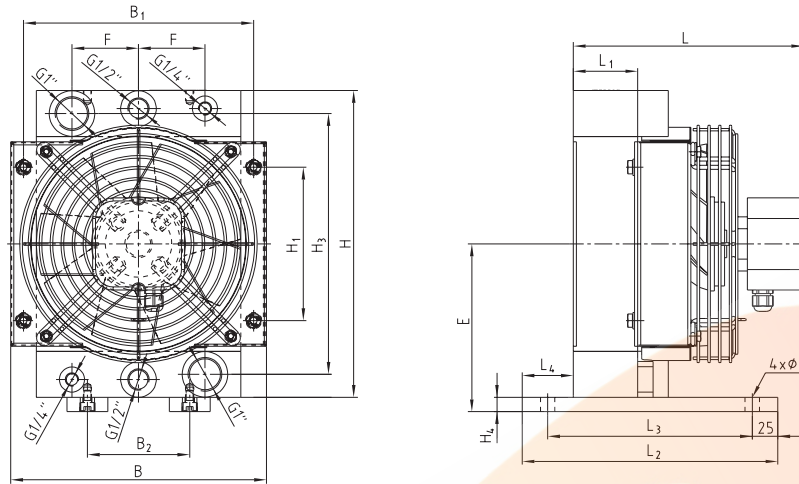

OAC100 - OAC400 230/400V (compact fan)

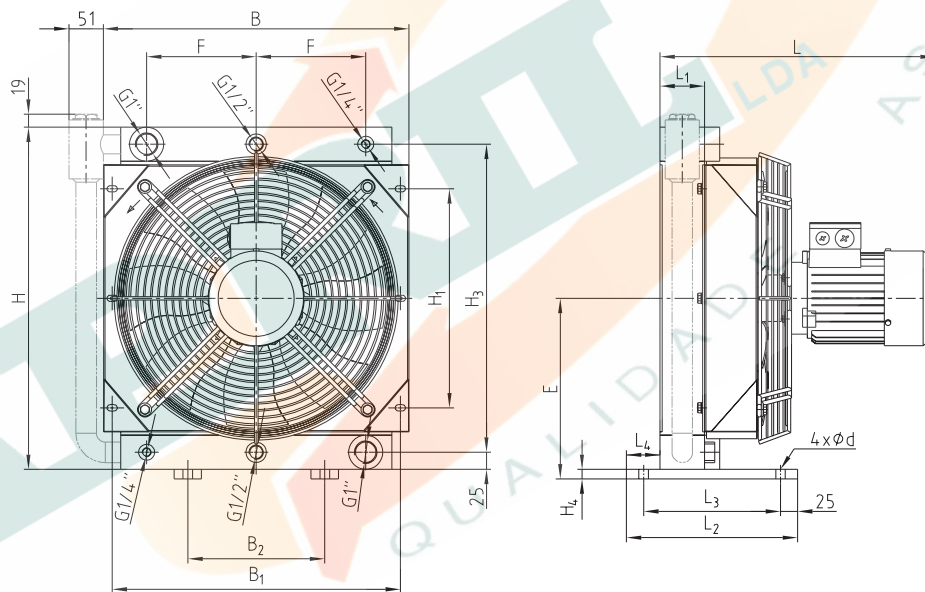

OAC200 - OAC400 230/400V

Oil/air cooler type OAC 230/400V																									
Type of cooler	Dimensions [mm]																				M	F	G	E	
	L	L ₁	L ₂	L ₃	L ₄	B	B ₁	B ₂	H	H ₁	H ₂	H ₃	H ₄	H ₅	d	d ₁	C ₁	C ₂	C ₃	C ₄					
OAC100-03 C	216	64	250	200	50	250	225	100	300	150	-	255	14	-	14	-	-	-	-	-	-	-	75	-	164
OAC200-03 C	279	64	250	200	50	350	325	174	410	240	-	360	14	-	14	-	-	-	-	-	-	-	115	-	219
OAC200-03	360	64	250	200	50	350	325	174	410	240	-	360	14	-	14	-	-	-	-	-	-	-	115	-	219
OAC250-03	390	95	280	230	56	350	325	174	410	240	-	360	14	-	14	-	-	-	-	-	-	-	115	-	219
OAC300-03-D	268	65	250	200	49	446	421	200	500	320	-	450	14	-	14	-	-	-	-	-	-	-	160	-	264
OAC300-03	402	65	250	200	49	446	421	200	500	320	-	450	14	-	14	-	-	-	-	-	-	-	160	-	264
OAC400-03-D	298	94	280	230	56	446	421	200	500	320	-	450	14	-	14	-	-	-	-	-	-	-	160	-	264
OAC400-03	432	94	280	230	56	446	421	200	500	320	-	450	14	-	14	-	-	-	-	-	-	-	160	-	264

Oil/air cooler type OAC Cooling systems

Dimensions of OAC500 - 2000 (230/400/690V)

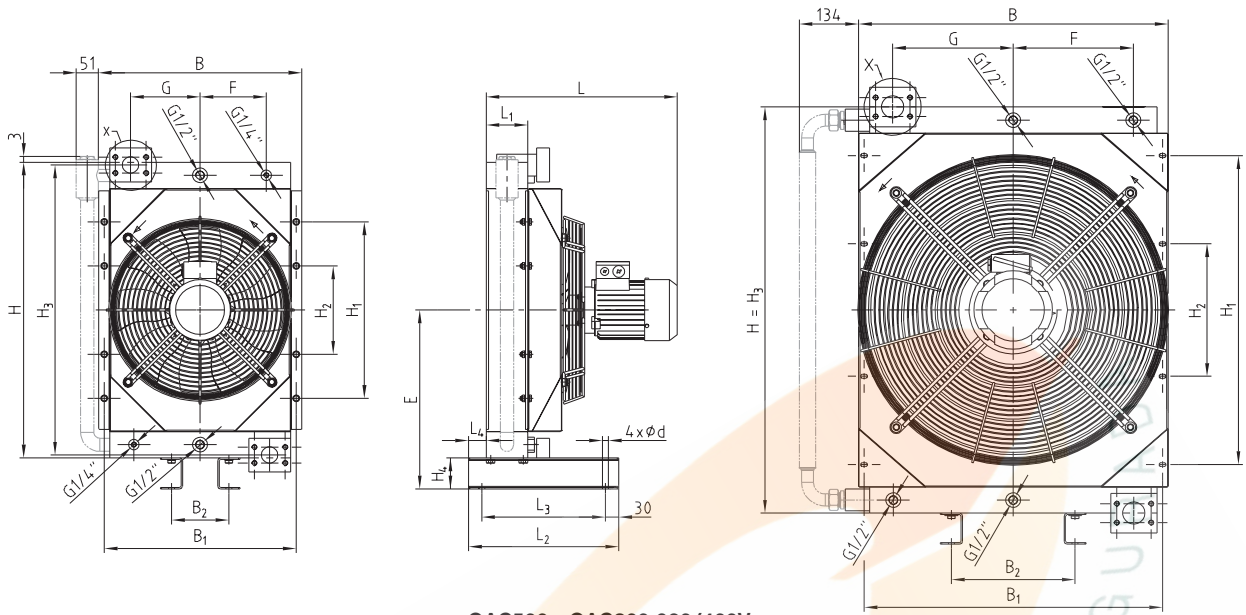

OAC500 - OAC800 230/400V

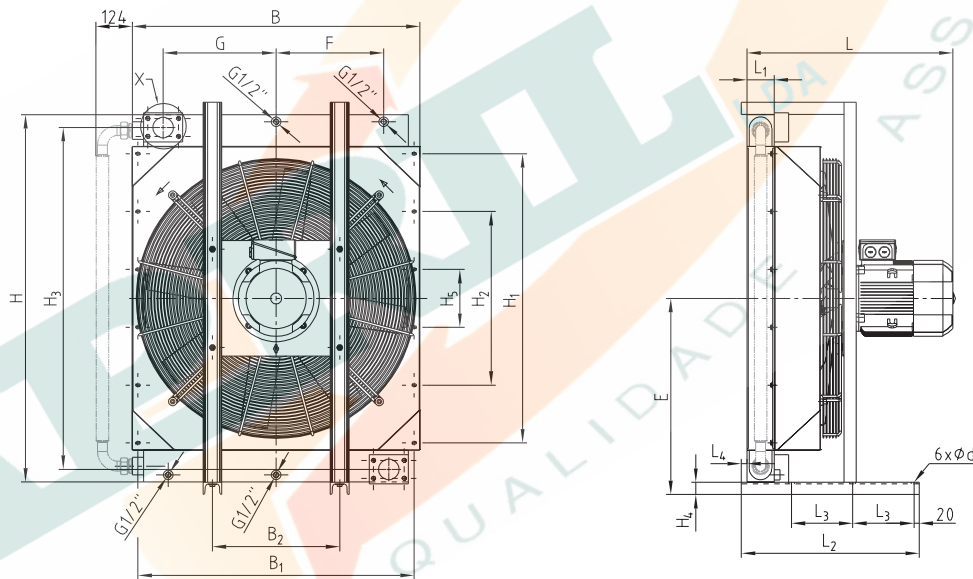

OAC850 - OAC2000 230/400V (400/690V)

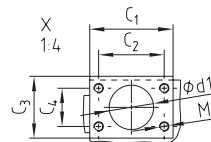

Oil/air cooler type OAC 230/400V																									
Type of cooler	Dimensions [mm]																								
	L	L ₁	L ₂	L ₃	L ₄	B	B ₁	B ₂	H	H ₁	H ₂	H ₃	H ₄	H ₅	d	d ₁	C ₁	C ₂	C ₃	C ₄	SAE flange	M	F	G	E
OAC500-03	431	94	340	280	40	460	435	130	670	400	200	657	70	-	13.5	38	95	69.9	77	35.7	1 1/2"	M12	150	157.5	405
OAC600-03	555	94	340	280	40	607	582	280	770	500	200	770	70	-	13.5	51	105	77.8	90	42.9	2"	M12	225	226	455
OAC700-03	565	94	340	280	40	608	582	280	920	700	300	920	70	-	13.5	51	105	77.8	90	42.9	2"	M12	225	226	530
OAC800-03	737	140	450	390	40	701	676	280	920	700	300	920	70	-	13.5	51	105	77.8	90	42.9	2"	M12	272	273	530
OAC850-03	734	94	500	180	-	870	835	350	960	690	230	910	42	-	14	51	105	77.8	90	42.9		M12	350	340	523
OAC900-03	670	95	590	210	-	995	955	440	1270	1000	600	1182	42	200	14	73	135	106.5	100	62		M16	372.5	390	678
OAC1000-03-06	690	113	615	210	-	995	955	440	1270	1000	600	1182	42	200	14	73	135	106.5	100	62		M16	372.5	390	678
OAC1000-03-04	729	113	615	210	-	995	955	440	1270	1000	600	1182	42	200	14	73	135	106.5	100	62	3"	M16	372.5	390	678
OAC2000-03-06	968	140	750	210	-	1286	1246	525	1420	1000	600	1332	45	200	14	73	135	106.5	100	62		M16	532	532	756
OAC2000-03-04	980	140	750	210	-	1286	1246	525	1420	1000	600	1332	45	200	14	73	135	106.5	100	62		M16	532	532	756

Oil/air cooler type OAC

Cooling systems

Dimensions of OAC200 - 800 (hydraulic)

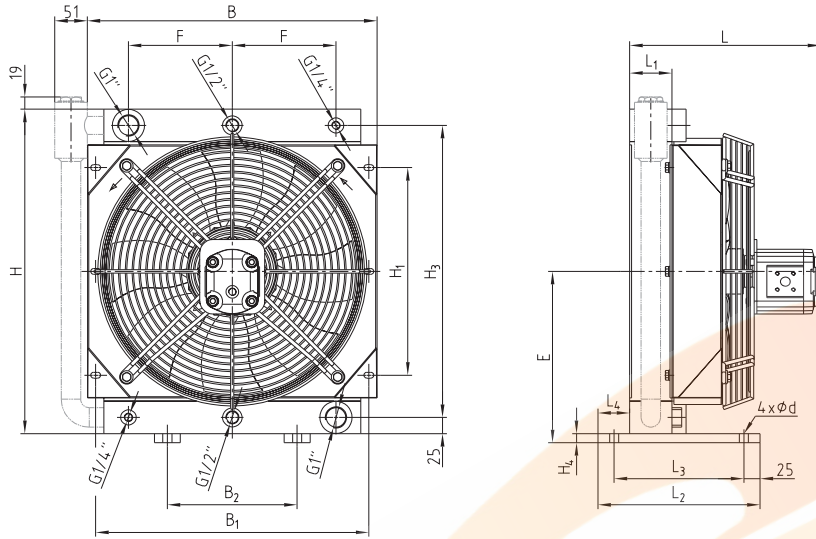

OAC200 - OAC400

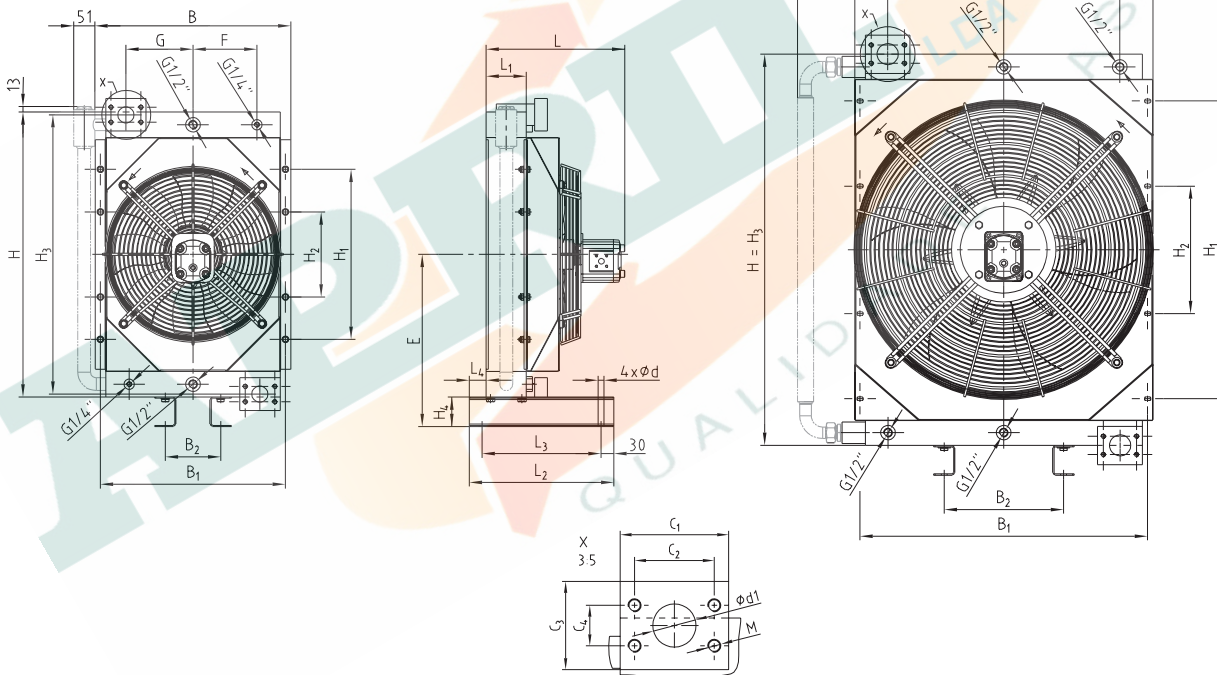

OAC500 - OAC700

OAC800

Oil/air cooler type OAC hydraulic																											
Type of cooler	Dimensions [mm]																				SAE flange	M	F	G	E		
	L	L ₁	L ₂	L ₃	L ₄	B	B ₁	B ₂	H	H ₁	H ₂	H ₃	H ₄	H ₅	d	d ₁	C ₁	C ₂	C ₃	C ₄							
OAC200-04	245	64	250	200	50	350	325	174	410	240	-	360	14	-	14	-	-	-	-	-	-	-	-	-	115	-	219
OAC250-04	275	95	250	200	50	350	325	174	410	240	-	360	14	-	14	-	-	-	-	-	-	-	-	-	115	-	219
OAC300-04	295	65	250	200	49	446	421	200	500	320	-	450	14	-	14	-	-	-	-	-	-	-	-	-	160	-	264
OAC400-04	325	94	280	230	55.5	446	421	200	500	320	-	450	14	-	14	-	-	-	-	-	-	-	-	-	160	-	264
OAC500-04	323	94	340	280	40	460	435	130	670	400	200	657	70	-	13.5	38	95	69.9	77	35.7	1 1/2"	M12	150	157.5	405		
OAC600-04	400	94	340	280	40	607	582	280	770	500	200	770	70	-	13.5	51	105	77.8	90	42.9		M12	225	226	455		
OAC700-04	411	94	340	280	40	608	582	280	920	700	300	920	70	-	13.5	51	105	77.8	90	42.9	2"	M12	225	226	530		
OAC800-04	546	140	450	390	40	701	676	280	920	700	300	920	70	-	13.5	51	105	77.8	90	42.9		M12	272	273	530		

Oil/air cooler type OAC

Cooling systems

Dimensions of OAC850 - 2000 (hydraulic)

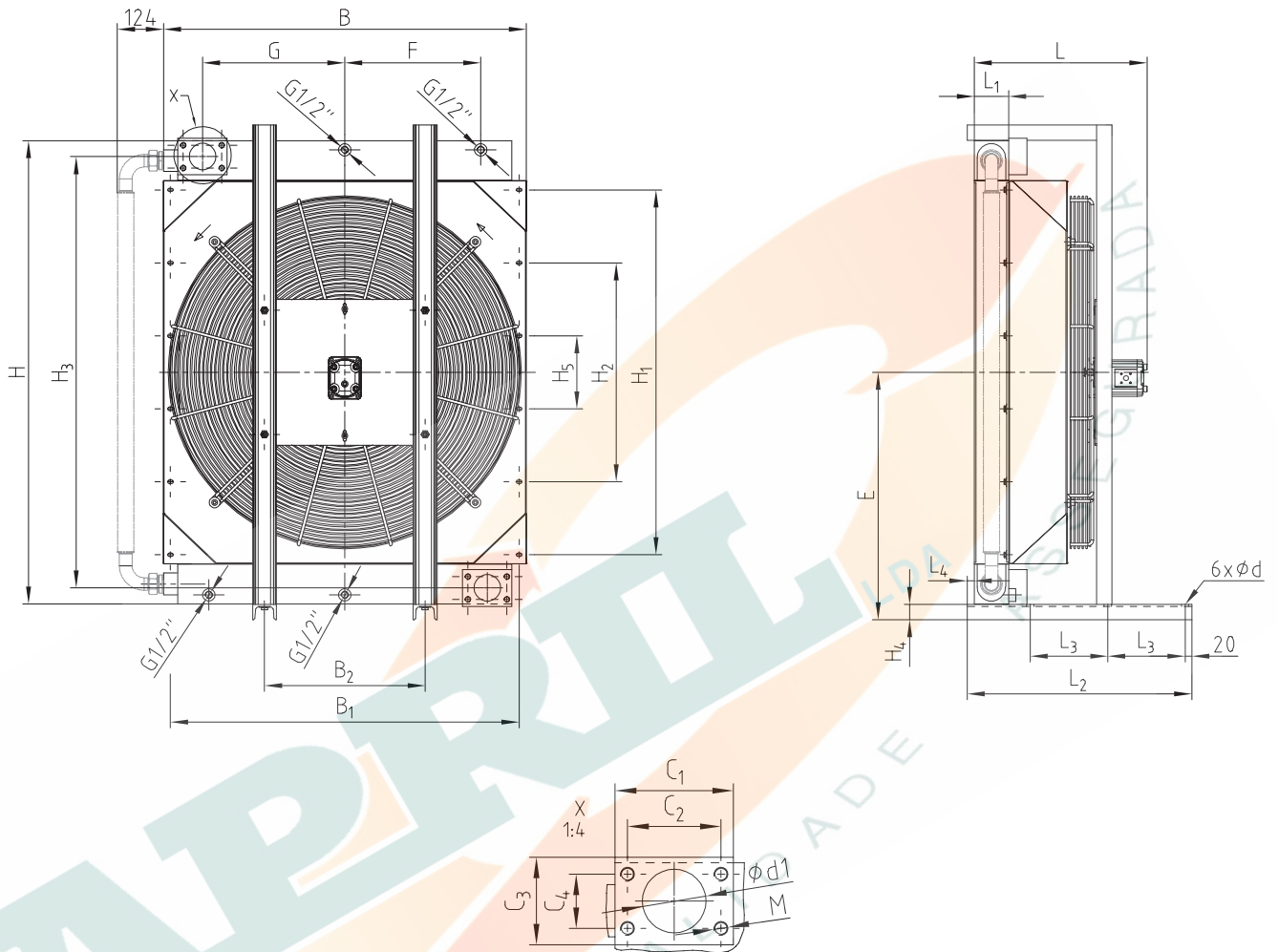

OAC850 - OAC2000

Oil/air cooler type OAC hydraulic

Type of cooler	Dimensions [mm]																										
	L	L ₁	L ₂	L ₃	L ₄	B	B ₁	B ₂	H	H ₁	H ₂	H ₃	H ₄	H ₅	d	d ₁	C ₁	C ₂	C ₃	C ₄	SAE flange	M	F	G	E		
OAC850-04	475	94	590	210	-	870	835	350	960	690	230	910	42	-	14	51	105	77.8	90	42.9	2"	M12	350	340	523		
OAC900-04	475	95	615	210	19.5	995	955	440	1270	1000	600	1182	42	200	14	73	135	106.5	100	62		M16	372.5	390	678		
OAC1000-04	505	113	615	210	-	995	955	440	1270	1000	600	1182	42	200	14	73	135	106.5	100	62	3"	M16	372.5	390	678		
OAC2000-04	620	140	750	210	-	1286	1246	525	1420	1000	600	1332	45	200	14	73	135	106.5	100	62		M16	532	532	756		

Oil/air cooler / cooling-pumping unit type OPC

Cooling systems

Bypass flow cooling with integrated pump



The OPC oil cooler unit is a system specifically developed for cooling in the bypass flow as an independent unit. The unit consists of a cooler, fan, electric motor, pump and may be supplemented by a filter on request of the customer.

Applications:

- Machine tools
- Elevators
- Test benches
- Add-on coolers
- Bypass flow cooling

Applicable for cooling of:

- Hydraulic oil
- Gear oil
- Lubricating oil
- Water glycol (min. 50 % glycol)

Structure:

- Cooler core (plate and bar) made of aluminium with industrial laminae in black (RAL 9005)
- Fan cover made of steel in black (RAL 9005)
- Fan made of nylon PAG
- Protective grid made of steel in black (RAL 9005)
- Electric motor 230/400V, IP55
- Bellhousing and coupling
- Gear feed pump with pressure relief valve 0 - 15 bars, recommended setting 5 bars,
 - max. medium temperature 90 °C (higher temperature on request),
 - low-noise pump, also for high viscosities
- Filter with visual maintenance display, as an option

Marine design:

- Cooler core, frame, fan cover with double-component paint
- Electric motor with special paint and protection class IP56

ATEX design:

- Gas sector: Ex II 2G Ex h IIC T6...T3 Gb X
- Dust sector: Ex II 3D Ex h IIIC T68 °C...110 °C Gb X
- Ambient temperature -40 °C < Ta < +55 °C
- Motor and fan as an adequate ATEX design

Accessories (see page 51 et seq.):

- Thermal bypass valves
- Oil thermostat valve (OTV)
- Protective grid
- Temperature switch (TSC)

The OPC coolers have to be protected from direct solar radiation.

Oil/air cooler / cooling-pumping unit type OPC

Cooling systems

Dimensions of OPC200 - 400 (230/400V)

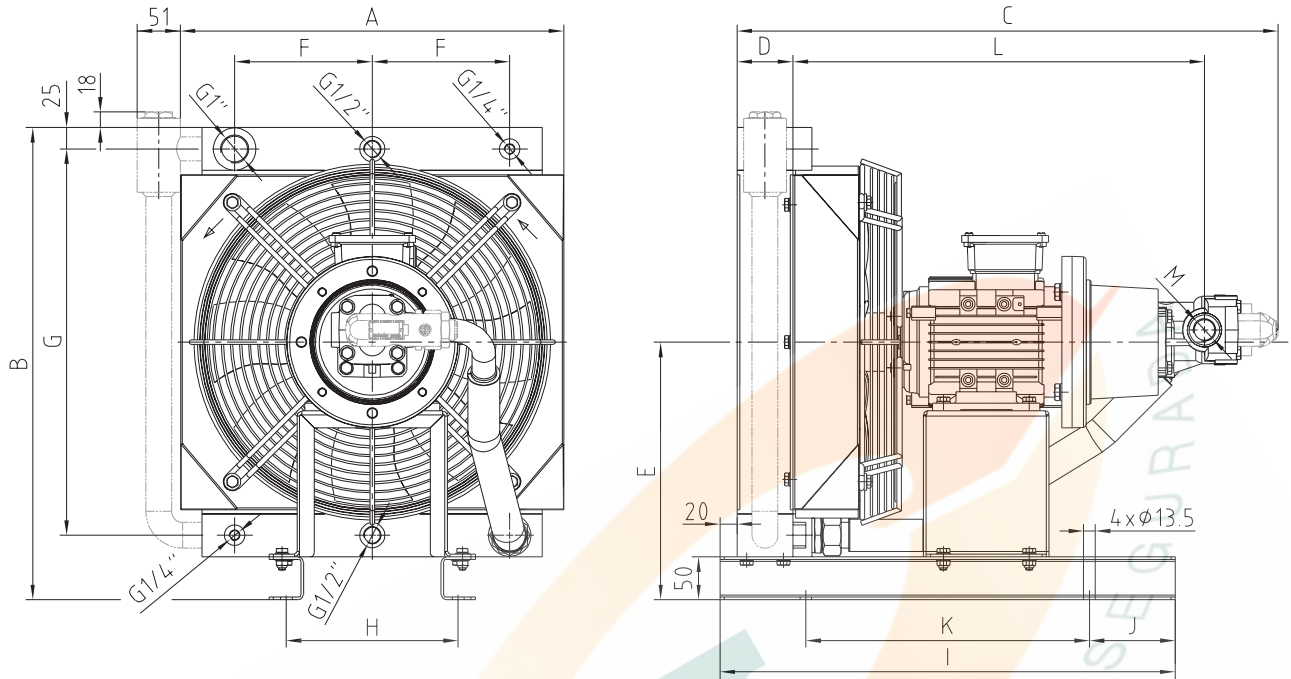

OPC200 - OPC400 for hydraulic applications (ISO VG32-68)

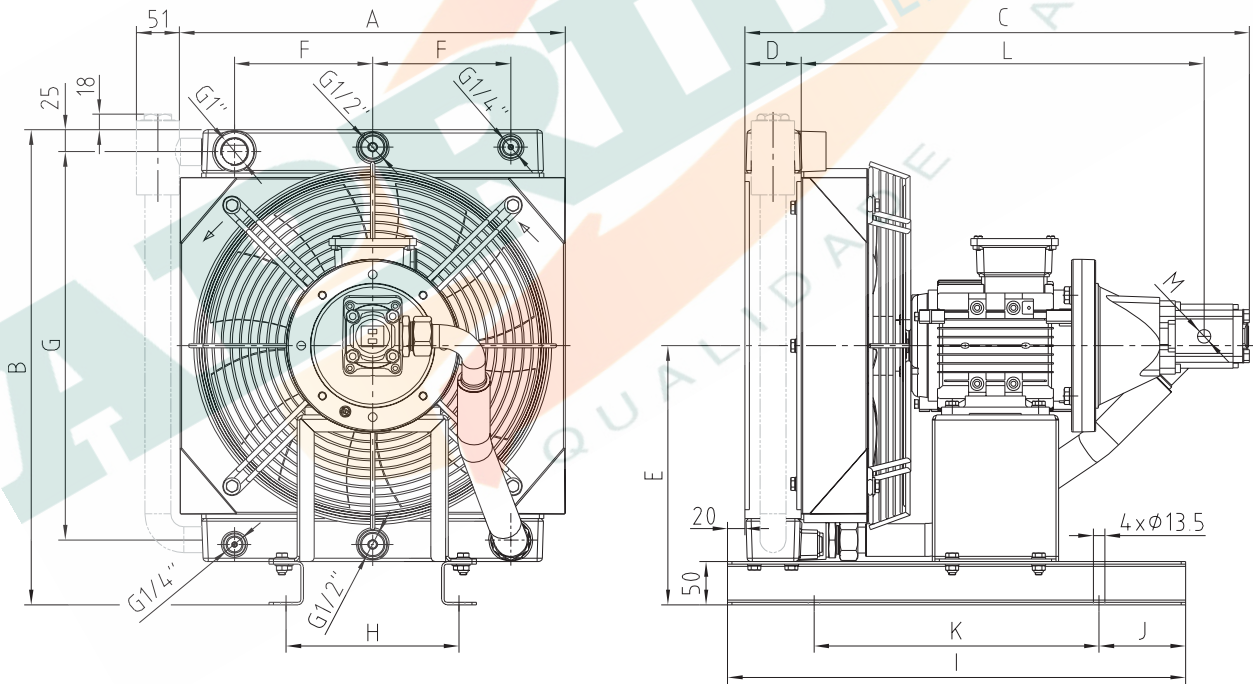

Technical data																				
Type of cooler	Voltage	Current [A]	Speed [rpm]	l/min	kW/°C	Dimensions [mm]											Weight [kg]			
						A	B	C	D	E	F	G	H	I	J	K		L	M	
OPC200-14-0.75kW	230/400V 50 Hz	1.8	1400	5.7	0.07	350	460	547	64	255	115	360	174	530	100	330	436	G 3/4"	35	
OPC200-18-0.75kW				11.5	0.09			572									426	G 3/4"		
OPC200-4D-0.75kW				5.5	0.07	350	460	572	596	65	300	160	450	200	530	100	330	426	G 3/4"	42
OPC200-12D-0.75kW				16.7	0.09			596										464	G 3/4"	
OPC200-16D-0.75kW				21.4	0.10	446	550	596	638	94	300	160	450	200	550	75	400	435	G 1"	45
OPC300-18-0.75kW				11.5	0.18			638										473	G 1"	
OPC300-114-0.75kW				20.1	0.23	446	550	615	622	94	300	160	450	200	550	75	400	476	G 1"	45
OPC300-4D-0.75kW				5.5	0.12			622										476	G 1"	
OPC300-12D-0.75kW				16.7	0.23	446	550	615	668	94	300	160	450	200	550	75	400	464	G 3/4"	45
OPC300-16D-0.75kW				21.4	0.25			668										474	SAE	
OPC400-114-0.75kW				20.1	0.26	446	550	615	668	94	300	160	450	200	550	75	400	476	G 1"	45
OPC400-12D-0.75kW				16.7	0.24			668										474	SAE	
OPC400-16D-0.75kW				21.4	0.27	446	550	615	668	94	300	160	450	200	550	75	400	474	SAE	45
OPC400-16D-0.75kW				21.4	0.27			668										474	SAE	

Oil/air cooler / cooling-pumping unit type OPC

Cooling systems

Dimensions of OPC500 - 600 (230/400V)

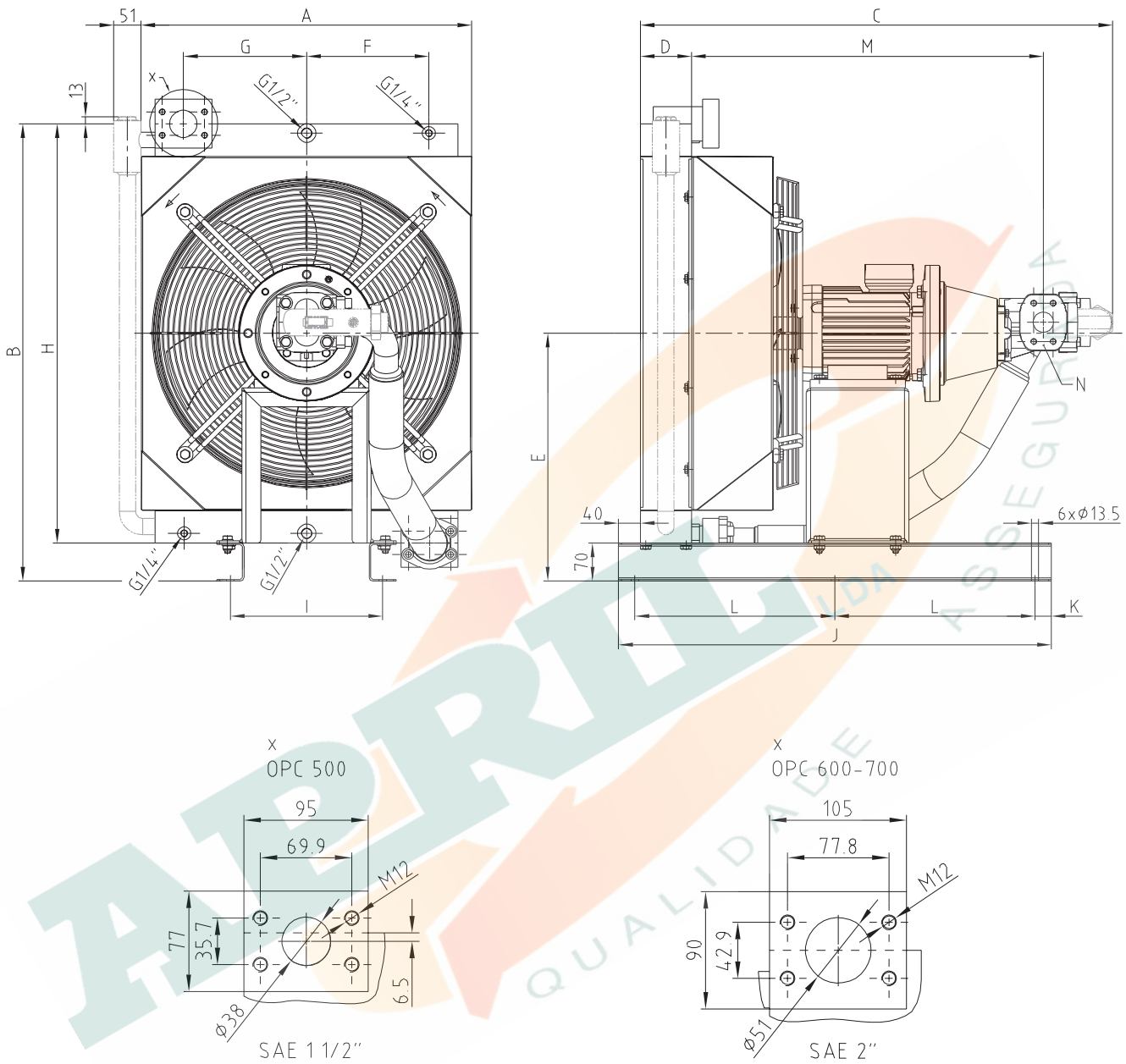

OPC500 - OPC600

Technical data																							
Type of cooler	Voltage	Current [A]	Speed [rpm]	l/min	kW/°C	Dimensions [mm]														Weight [kg]			
						A	B	C	D	E	F	G	H	I	J	K	L	M	N				
OPC500-16D-2.2kW	230/400V 50 Hz	4.9	1410	21.4	0.35	460	740	740	94	405	150	157.5	657	130	720	30	330.0	547	G 1"	75			
OPC500-25D-2.2kW				33.4	0.40			790										568	SAE 1 1/2"	77			
OPC500-32D-2.2kW				42.7	0.42	819	607	840	94	455	225	226.0	770	280	795	30	367.5	626	G 1"	96			
OPC500-40D-2.2kW				53.5	0.45													868	647	SAE 1 1/2"	98		
OPC600-16D-2.2kW							21.4	0.47			819										626	G 1"	96
OPC600-25D-2.2kW							33.4	0.56			840										607		
OPC600-32D-2.2kW							42.7	0.61															
OPC600-40D-2.2kW							53.5	0.66															

Oil/air cooler / cooling-pumping unit type OPC

Cooling systems

Dimensions of OPC800 - 1000 (400/690V)

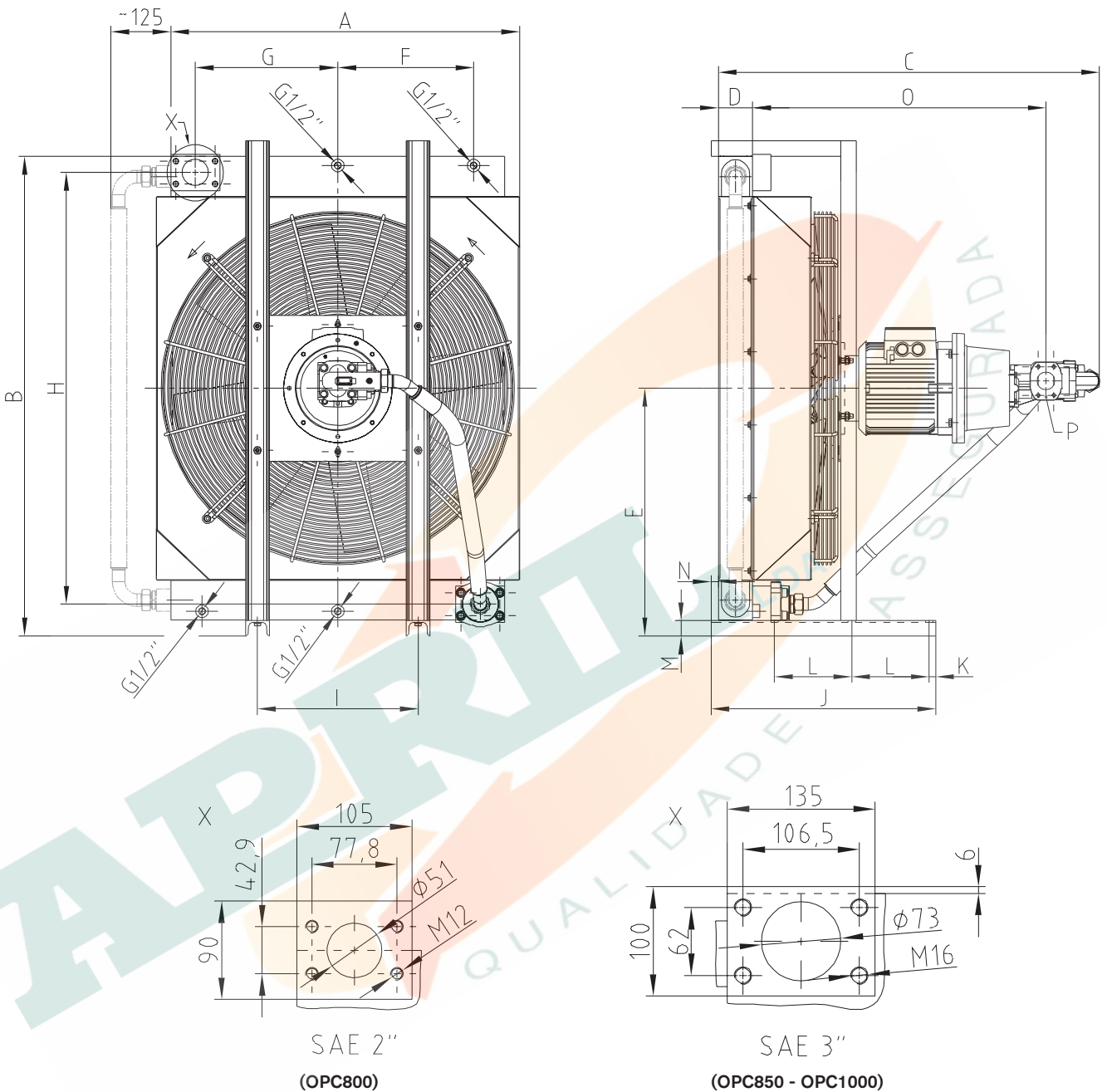

OPC800 - OPC1000 (400/690V)

Technical data																				
Type of cooler	Voltage	Current [A]	Speed [rpm]	l/min	kW/°C	Dimensions [mm]														Weight [kg]
						A	B	C	D	E	F	G	H	I	J	K	L	M	N	
OPC800-50D-4kW	400/690V 50 Hz	8.2	1460	69	1.00	701	981	1096	140	521	350	340	920	280	670	292	829	112		
OPC800-80D-4kW				112	1.15	1130	845	113												
OPC850-80D-5.5kW				72	1.12	1046	804	146												
OPC850-125D-5.5kW		12	970	113	1.32	870	1002	1081	94	523	910	350	590	180	824	63.5	160			
OPC900-80D-5.5kW				72	1.34	1046	804	189												
OPC900-125D-5.5kW		113	1.71	1081	995	1312	1119	113	678	373	390	1182	440	615	210	824	63.5	203		
OPC1000-125D-5.5kW		113	1.88	1119												844	217			
OPC1000-180D-5.5kW		167	2.33	1136	1136	1136	1136	1136	1136	1136	1136	1136	1136	1136	1136	1136	854	76.2	220	

Oil/air cooler / cooling-pumping unit type OPC2

Cooling systems

Dimensions of OPC2-300 - 900 (230/400V)

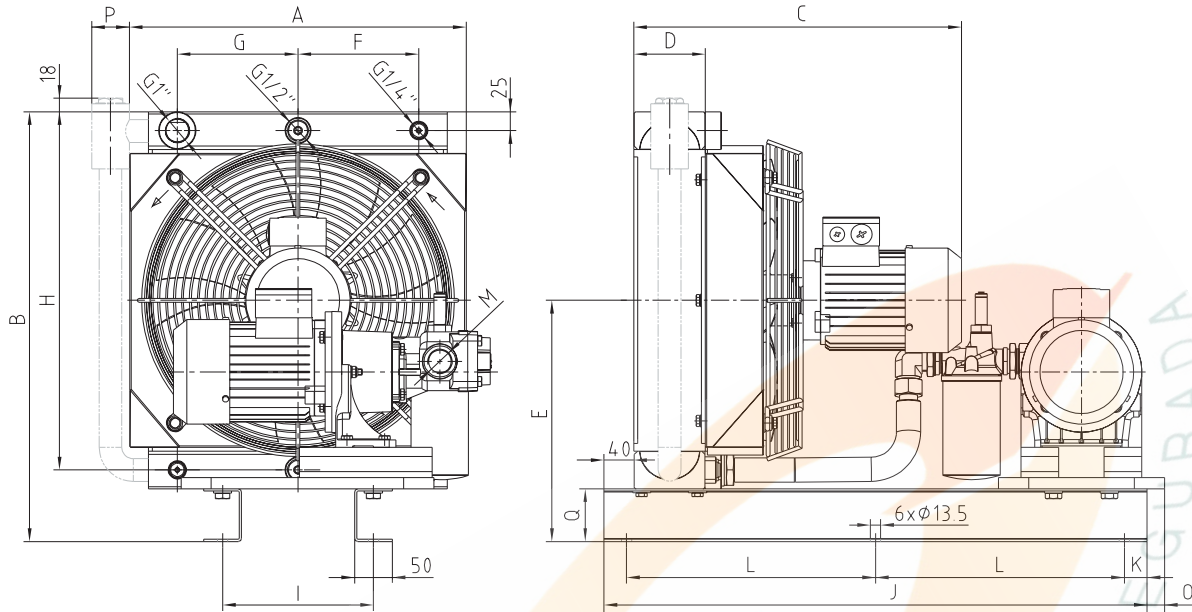

OPC2-300 - OPC2-400

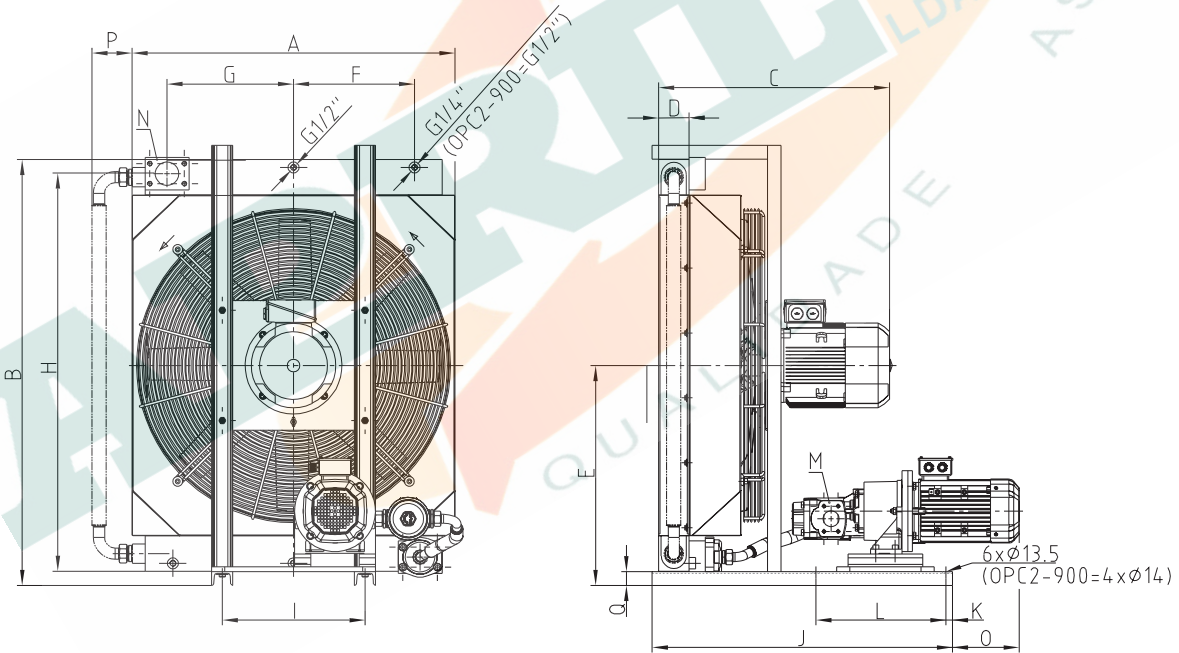

OPC2-500 - OPC2-900

Technical data

Type of cooler	Voltage	Engine Coolers		Engine Pump		Flow rate		Dimensions											Weight [kg]								
		Current* [A]	Speed [rpm]	Current* [A]	Speed [rpm]	[l/min]	kW/°C	A	B	C	D	E	F	G	H	I	J	K		L	M	N	O	P	Q		
OPC2-300-4	230/400V 50Hz (460V 60Hz)	1.03	1385	1.03	1385	5.5	0.13												G ^{3/4"}					53			
OPC2-300-12							17	0.21	446	570	417										G ^{1"}	G ^{1"}				63	
OPC2-400-16							21.6	0.27																			66
OPC2-400-32							44	0.36																23	51	70	66
OPC2-500-32					44	0.46																			74		
OPC2-500-63					460	740	448		405	150	157.5	670	130						SAE 1 1/2"	SAE 1 1/2"					81		
OPC2-700-40					3.43	1445	88	0.54																	117		
OPC2-700-100					1.77	1420	53.5	0.76	607	990	563	94	530	225	226	920	280	795		367.5	SAE 2"	SAE 2"			139		
OPC2-900-63					4.83	1440	141	0.98												SAE 2"	SAE 2"	340			139		
OPC2-900-63					5.3	955	3.43	1445	88	1.50	995	1313	712		678	372.5	390	1270	440	925	20	400	SAE 1 1/2"	SAE 3"	227	125	42
OPC2-900-100				4.83	1440	141	1.91												SAE 2"	SAE 3"	206			275			

x basis 400V

Oil/air cooler / cooling-pumping unit type OPC

Cooling systems

Type code of industrial cooler oil/air

OPC 200 M - 4D - 0.75 kW - A - F10 - 0 - 0

Size of cooler	Type	Nominal size of pump incl. type	Motor power	Voltage	Filter	Bypass	Protective grid against stones
100	No specification = Standard	e. g.: 4D	0.75 kW	A = 230/400V 50 Hz or 460V 60 Hz (up to OPC600)	To be omitted if not applicable	0 = Without bypass	0 = No 1 = Yes
200			2.2 kW				
300	M = Marine (seawater resistance)		4 kW	B = 400/690V 50 Hz	F10 = Filter (permeability up to 10µ) with visual display	TB6 = Thermal bypass (6 bars/50 °C)	
400			5.5 kW				
500	ExG = ATEX (gas-protected area)	e. g.: 4D		Z = Special voltage*	F25 = Filter (permeability up to 25µ) with visual display	DB6(F) = Pressure bypass (2, 4, 6 bars)	
600							
700	ExD = ATEX (dust-protected area)						
800							
900	M-ExG = Marine & ATEX (gas)						
1000							
	M-ExD = Marine & ATEX (dust)						

* Special voltage in plain language

OPC2 - 400 M - 16 - 0.75-4 / 0.37-4 - Z - F10 - DB4 - 1

Size of cooler	Type	Nominal size of pump incl. type	Motor power - pole number of pump	Motor power - pole number of cooler	Voltage	Filter	Bypass	Protective grid against stones
200	No specification = Standard	e. g.: 16	e. g.: 0.75 kW	e. g.: 0.37 kW	A = 230/400V 50 Hz or 460V 60 Hz	To be omitted if not applicable	0 = Without bypass	0 = No 1 = Yes
300								
400	M = Marine (seawater resistance)				B = 400/690V 50 Hz or 460V 60 Hz	F10 = Filter (permeability up to 10µ) with visual display	TB6 = Thermal bypass (6 bars/50 °C)	
500								
600					Z = Special voltage*	F25 = Filter (permeability up to 25µ) with visual display	DB6 = Pressure bypass (2, 4, 6 bars)	
700								
800								
850								
900								
1000								
2000								

* Special voltage in plain language

Oil/air cooler OAC / cooling-pumping unit type OPC

Cooling systems

Cooler accessories

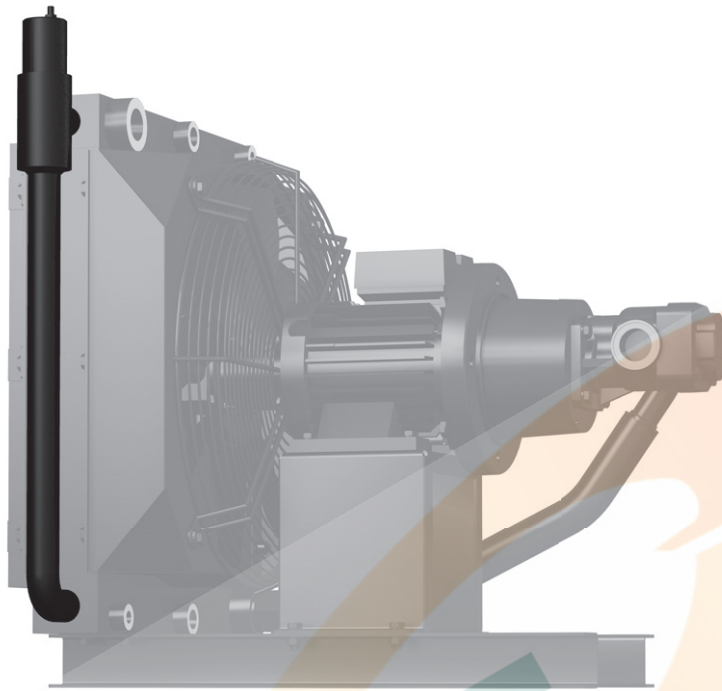

Thermal & pressure bypass (TB)

The integrated thermal and pressure bypass additionally provides for faster return of the oil passing the cooler core to reach the operating temperature efficiently through the load. Safeguarding the pressure is assured in parallel.

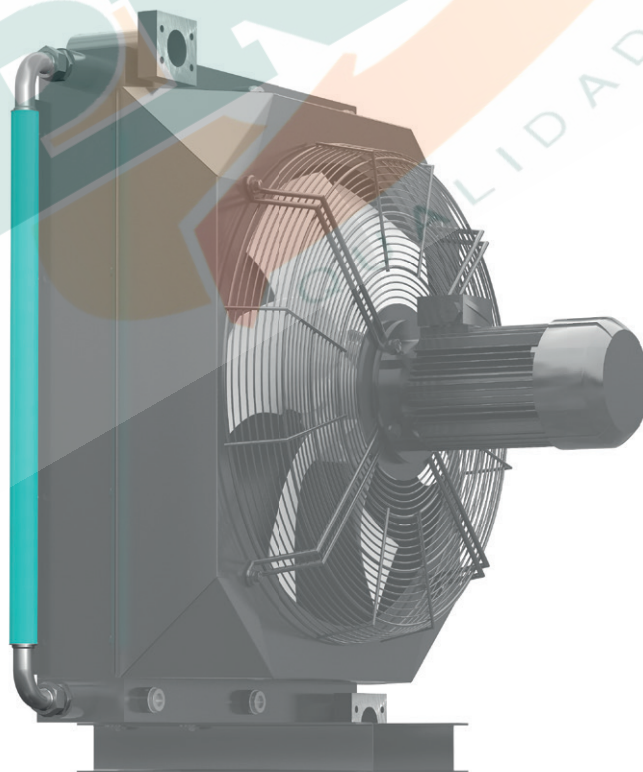

Pressure bypass (DB)

Integrated pressure bypass protecting the cooler core against excess pressure. A share of the volume flow is bypassed along the cooler core depending on the opening pressure.

Oil/air cooler type OAC

Cooling systems

Cooler accessories

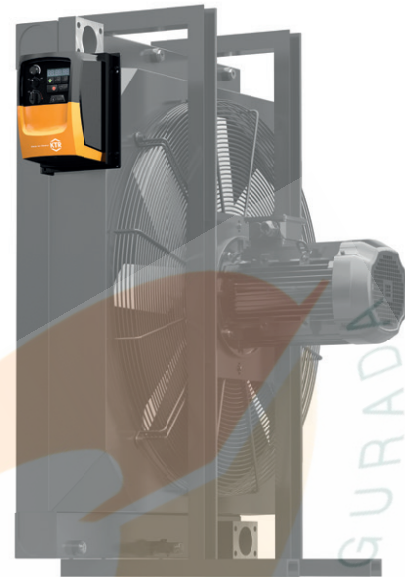

Soft start-up control and variable-speed operation for coolers with direct current motors (12 & 24V)

The soft start-up makes sure the motor exceeds the nominal current consumption by a maximum of 10 %, the motor accelerates slowly with increasing temperatures not overloading the current supply. Depending on temperature the motor makes sure that only as much cooling capacity as actually needed is provided. The motor starts from an oil inlet temperature of 40 °C reaching its max. speed with 60 °C.

An automatic reverse operation can be integrated in the control unit to purge the cooler core.

An existing cooler can be retrofitted or provided with the control unit immediately ex works.

Frequency converter operation for coolers with three-phase motors

All coolers can be supplied with frequency converter ex works to reduce the noise emissions. The oil inlet temperature is used as a signal for the frequency converter via PT100 to reduce or increase the speed, if necessary. Appropriate ramps are pre-installed or can be defined by the customer. This allows the motor to run a frequency band from 35 - 50 Hz or run up to 60 Hz with an adequate motor dimensioning to provide for sufficient reserve with temperature peaks.

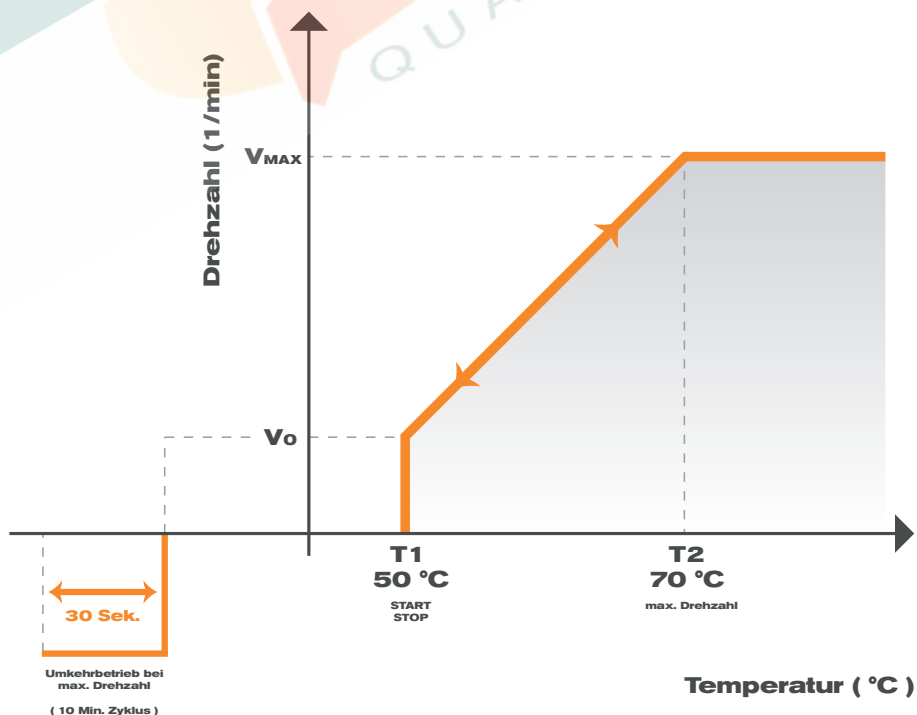

Oil/air cooler accessories

Cooling systems

Oil thermostat valve

A: Pump
B: Load

C: Governor valve
D: Cooler

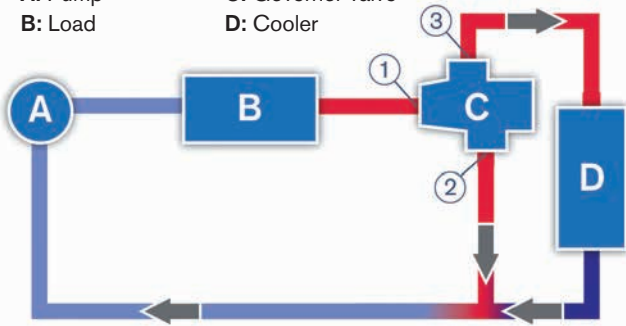

Use as a short circuit control:
Constant temperature on load outlet

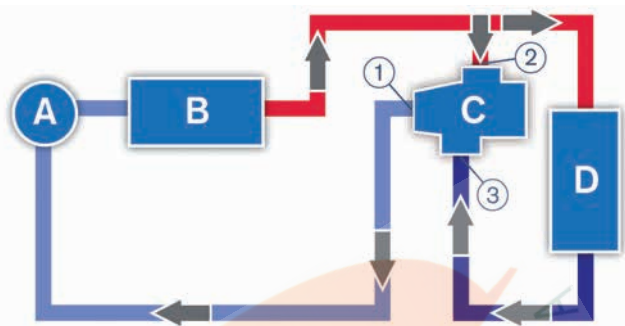

Use as a mixing valve:
constant temperature on load inlet

Main applications of oil thermostat valves

- Agricultural machines
- Construction machines
- Compressors
- Coolers
- Special applications, e. g. wind turbines, gearboxes, hydraulics, general engineering

Particular characteristics

- non-adjustable temperature figures
- high control accuracy
- control operation regardless of static and dynamic oil pressure
- low pressure loss
- sound design
- insensitive to vibrations
- insensitive to shocks
- operation independent of the mounting situation
- maintenance-free
- long service life

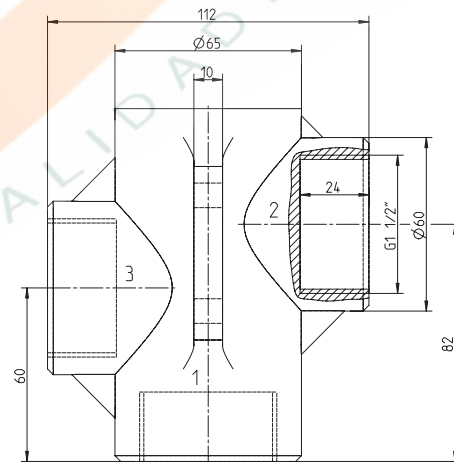
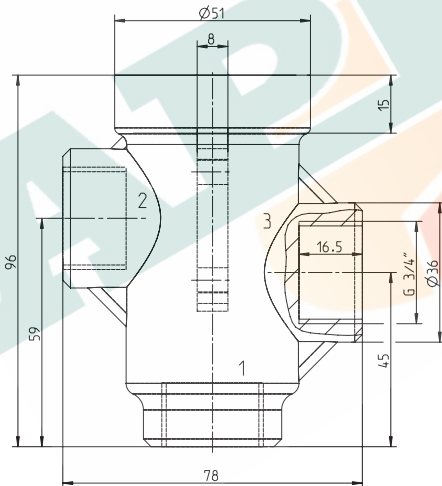

OTV Oil thermostat valve				
Description	Max. volume flow [m³/h]	Connection thread	Inlet temperature [°C]	Max. inflow to the cooler obtained with °C
OTV1-45	4	G 3/4"	45	60
OTV1-55	4	G 3/4"	55	70
OTV1-70	4	G 3/4"	70	85
OTV2-45	10	G 1 1/2"	45	60
OTV2-55	10	G 1 1/2"	55	70
OTV2-70	10	G 1 1/2"	70	85

Max. operating pressure 16 bars

Ordering example:	OTV	1	55
	Oil thermostat valve	Size	Inlet temperature

TEMPERATURE CONTROL AND MONITORING HYDRAULIC COMPONENTS

Cooler accessories - filters

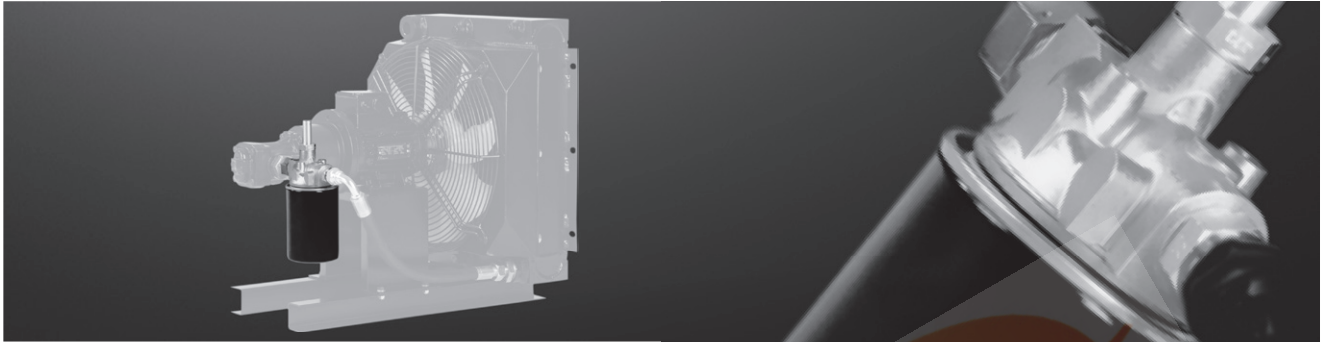

Single or double filter with mounting cartridge and visual display for separating dirt particles.

Options:

- 10 µm or 25 µm depending on volume flow, oil type and temperature
- Filter attachment for electrical signals available
- Protective coating for use with salty ambient air



Cooler accessories - temperature switch TSC

Technical data		
Switching element:	Bi metal	Switching point:
Switching operation:	NO = make contact	TSC 40 = 40 °C
Switching temperature:	+25 °C to +80 °C	TSC 50 = 50 °C
Material of probe:	Brass	TSC 60 = 60 °C
Max. operating pressure:	26 bars	TSC 70 = 70 °C
Operating temperature:	20 °C to +100 °C	
Plug:	According to DIN 43650 - 3 poles + PE, protection class IP65, cable gland PG11	

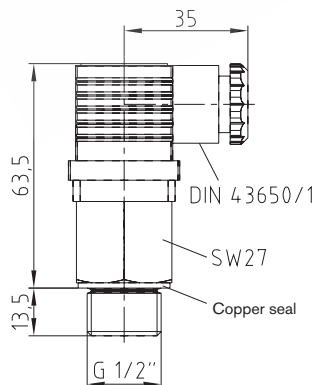

- Simple, solid design
- Electrical insert easy to disassemble
- With plug acc. to DIN 43650 straight cable outlet direction rotatable by 360°
- Copper seal
- Protection class IP65

Temperature contacts:	Max. operating voltage:	250V AC - 8 A 24V DC - 5A
	Max. switching current:	2 A
	Tolerance:	±5 K
	Switch-back difference:	15 K ±3 K

Ordering example:

TSC	50
Temperature switch	Switching point 50 °C

Oil/air cooler / cooling-pumping unit type OPC

Cooling systems

Cooler accessories

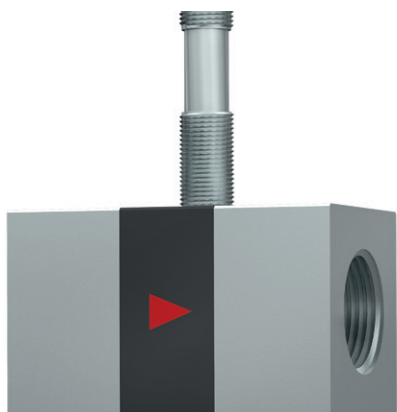

Flow switch

- Measuring range 1 - 50 l/min (other on request)
- G 1" connection thread
- Supply voltage 10 - 30 V DC



Pressure display

- Manometer for inspecting the current operating pressure

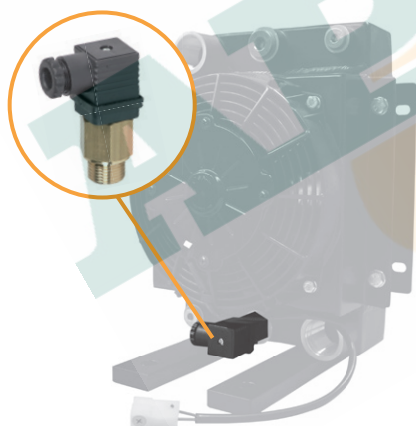

Pressure switch

- Adjustable from 1 - 16 bars
- G1/4" connection thread
- Applicable on cooler inlet or outlet

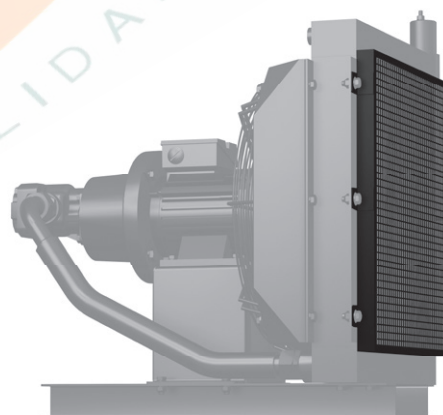

Protective grid

Protection against rough damages of cooling laminas via corrugated wire mesh (10 x 10 mm). Optionally a filter pad is available protecting against smaller particles (dust, sand). Please consider a reduction of performance depending on load.

Oil/air cooler type PIK

Cooling systems

Bellhousing with integrated oil/air cooler

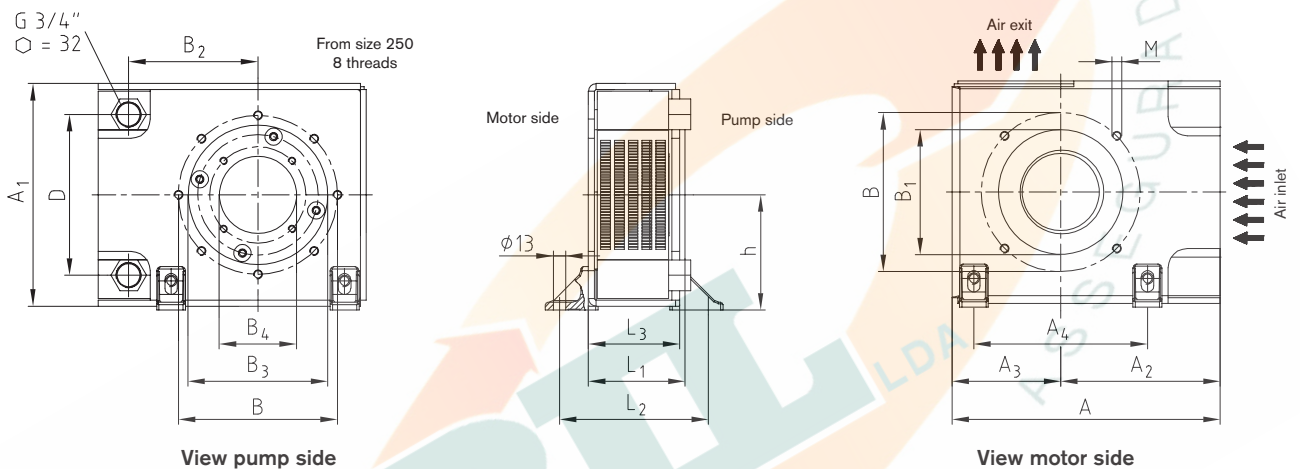

Bellhousing with integrated oil/air cooler type PIK (German utility model)

IEC motor		PIK oil cooler type	Dimensions [mm] *															
Size (shaft)	kW with 1500 rpm		L ₁	L ₂	L ₃	A	A ₁	A ₂	A ₃	A ₄	B	B ₁	B ₂	B ₃	Min. B ₄	D	M	h
80	0.55	PIK 200/1/...	100	154.5	94.5	275	225	163	112.5	180	165	130	130	145	20	167	M10	116.5
(19 x 40)	0.75	PIK 200/2/...	110	154.5	94.5	275	225	163	112.5	180	165	130	130	145	20	167	M10	116.5
90S/90L	1.1	PIK 200/4/...	124	154.5	94.5	275	225	163	112.5	180	165	130	130	145	20	167	M10	116.5
(24 x 50)	1.5																	
100L/112M	2.2	PIK 250/2/... **	124	175.5	115.5	308	250	180	125	220	215	180	150	190	20	192	M12	129
(28 x 60)	3, 4	PIK 250/4/... **	135	175.5	115.5	305	250	180	125	220	215	180	150	190	20	192	M12	129
132S/132M	5.5	PIK 300/1/...	144	199.5	139.5	359	300	205	154	260	265	230	175	234	30	242	M12	154
(38 x 80)	7.5	PIK 300/3/...	155	199.5	139.5	359	300	205	154	260	265	230	175	234	30	242	M12	154
		PIK 300/4/...	168	199.5	139.5	359	300	205	154	260	265	230	175	234	30	242	M12	154
160M/160L	11	PIK 350/1/... **	188	243.5	183.5	405	360	230	175	310	300	250	200	260	50	292	M16	184
(42 x 110)	15	PIK 350/2/...	204	243.5	183.5	405	360	230	175	310	300	250	200	260	50	292	M16	184
180M/180L	18.5																	
(48 x 110)	22																	

* Dimensions following the VDMA standard 24561

** In case of a motor speed of ≥ 1900 rpm a steel fan must be used.

Assembly

With assembly and disassembly of the oil connection lines hold up with a hexagon key (max. tightening torque 40 Nm). No reduction of the cross section behind the cooler. Return filters to be installed in front of the cooler (dynamic pressure, danger of bursting). Tensions inside the connection pipes have to be avoided! Vibration of the piping has to be avoided (should possibly be intercepted in front of the connector). Supply and discharge to be chosen alternatively. Please note that not a few hydraulic systems generate pressure peaks of more than 12 bars in the return flow (danger of bursting)! Please observe our assembly instructions at www.ktr.com.

For PIK sizes 200 and 350 specify the IEC motor sizes in your order.

Ordering example:	PIK	300	3	5	15
	Bellhousing with integrated oil cooler	Flange diameter of IEC motor	Serial model code (code referring to length)	In-house modification code	Standard type 15 - V1 design

Oil/air cooler type PIK Cooling systems

Oil/air cooler type PIK 200 - 350

1. Cooling capacity for a speed of 1500 rpm depending on the temperature difference between oil intake and air intake and oil volume

PIK 200

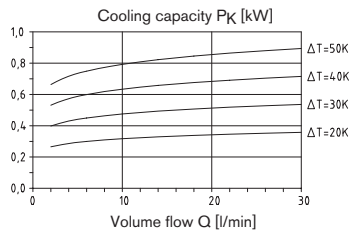

PIK 250

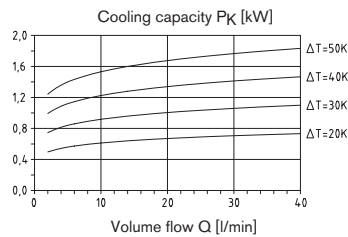

PIK 300

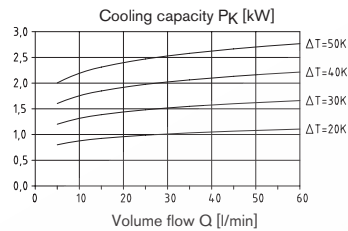

PIK 350

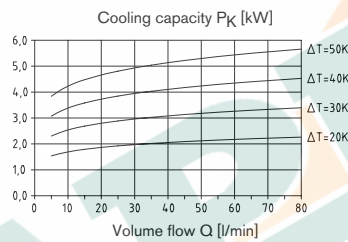

The diagrammes shown are based on actual measurements of the PIK oil cooler performed in KTR's in-house R&D test center. With 3000 rpm the cooling capacity is increased by approx. 50 %.

2. Operating pressure

The permissible operating pressure of the oil cooler is 12 bars dynamically. Max. operating pressure with static load 20 bars (all values apply for the average pressure cooler).

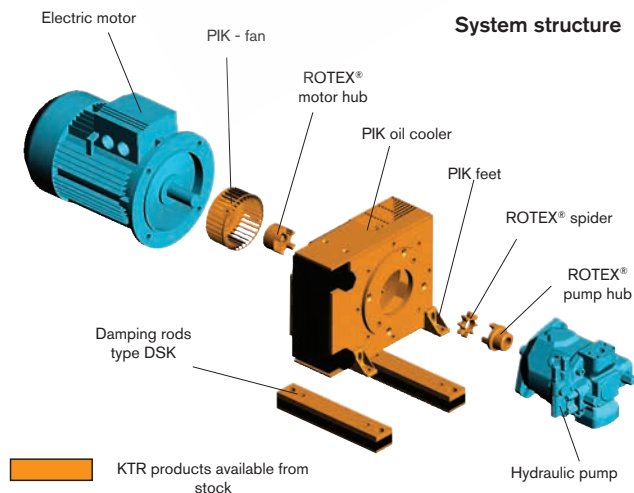

3. Pressure difference depending on oil flow and oil viscosity

PIK 200

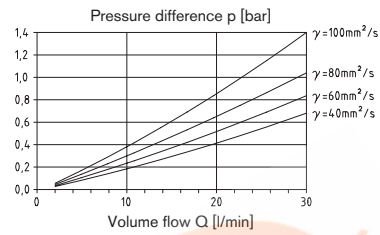

PIK 250

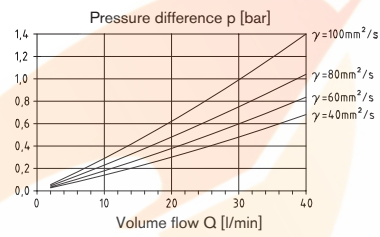

PIK 300

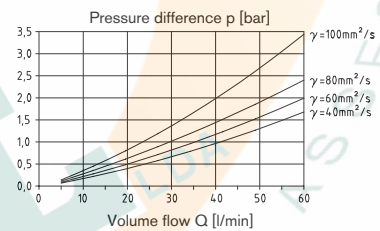

PIK 350

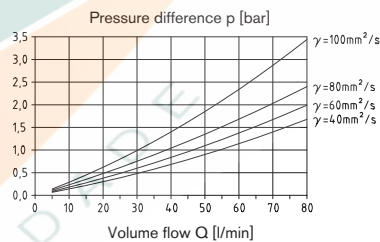

Viscosity measured up to 100 mm²/s.
Higher viscosity on request.

4. Fan

Torsional direction view onto the pump – **right** – standard type.

Performance requirement of the fan with 1500 rpm

PIK 200 = 25 W

PIK 250 = 40 W

PIK 300 = 125 W

PIK 350 = 230 W

Air pressure rate in m³/h with 1500 rpm

PIK 200 = approx. 90 m³/h

PIK 250 = approx. 200 m³/h

PIK 300 = approx. 400 m³/h

PIK 350 = approx. 860 m³/h

5. Cooler connection

R 3/4" internal thread

6. Oil flow

With an oil flow exceeding the figures stated in the above diagramme, please consult with our engineering department. Phone: +49 5971 798-0

Oil/water cooler type PHE

Cooling systems

High power density in a tight space

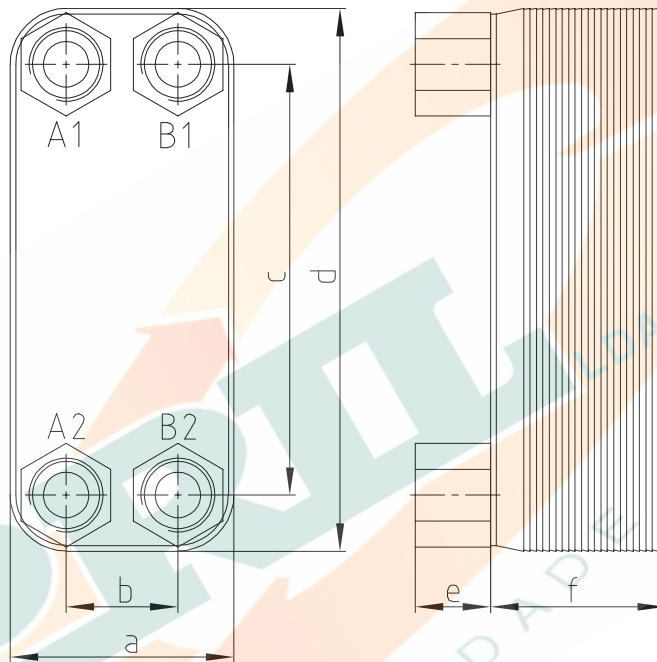
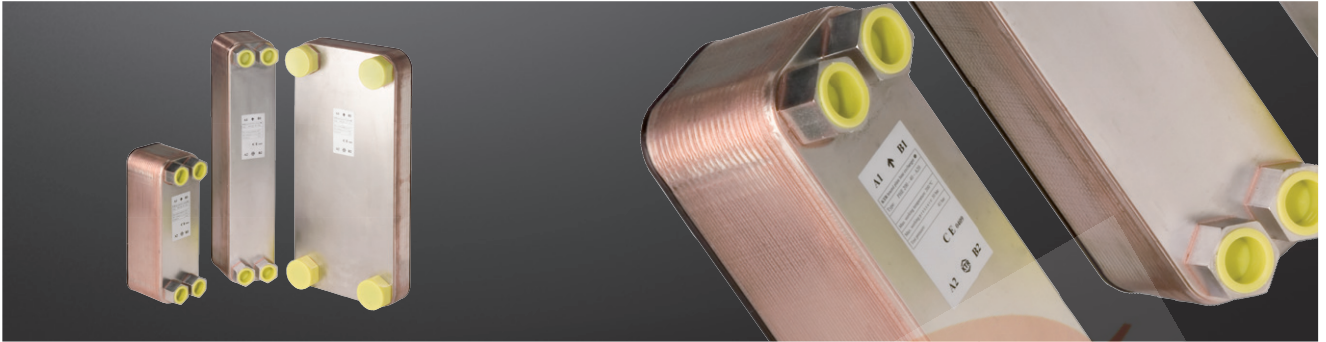

Technical data

Plate heat exchanger made of stainless steel 1.4401 soldered with copper. The stamped plates generate a high power density in a tight space. Compared to a tube bundle heat exchanger, the plate heat exchanger only requires approx. 25 % - 30 % of mounting space with less weight. Applications are, as an example, machine tools, test benches, moulding machines, pump units, waste heat utilization, etc. It is possible to use other media like, for example, oil, water glycol, water, refrigerating agents, air, etc.

Operating temperature: -10 °C to +200 °C.

Please observe boiling point and freezing point!

Maximum permissible operating pressure: PHE 100: 10 bars / PHE 200 - 500: 30 bars

Plate heat exchanger									
Series	Size	Thread	Plates	a	b	c	d	e	f
PHE	100	4 x 3/4"	20	73	40	154	191	24	52
PHE	100	4 x 3/4"	40						97
PHE	200	4 x 1"	20						55
PHE	200	4 x 1"	40	116	72	243	286	24	103
PHE	200	4 x 1"	60						151
PHE	300	A1/A2: G1 1/4" B1/B2: G1"	40	119	72	479	526	27	100
PHE	300	4 x 1"	50	107	50	466	523	24	128
PHE	300	A1/A2: G1 1/4" B1/B2: G1"	60	119	72	479	526	27	145
PHE	300	A1/A2: G1 1/4" B1/B2: G1"	80	119	72	479	526	27	190
PHE	500	4 x 1 1/2"	40						103
PHE	500	4 x 1 1/2"	60	191	92	519	616	30	151

Ordering example:	PHE	100	20
	PHE = Plate heat exchanger	Size	Number of plates

Oil/air cooler

Cooling systems

Cooling capacity

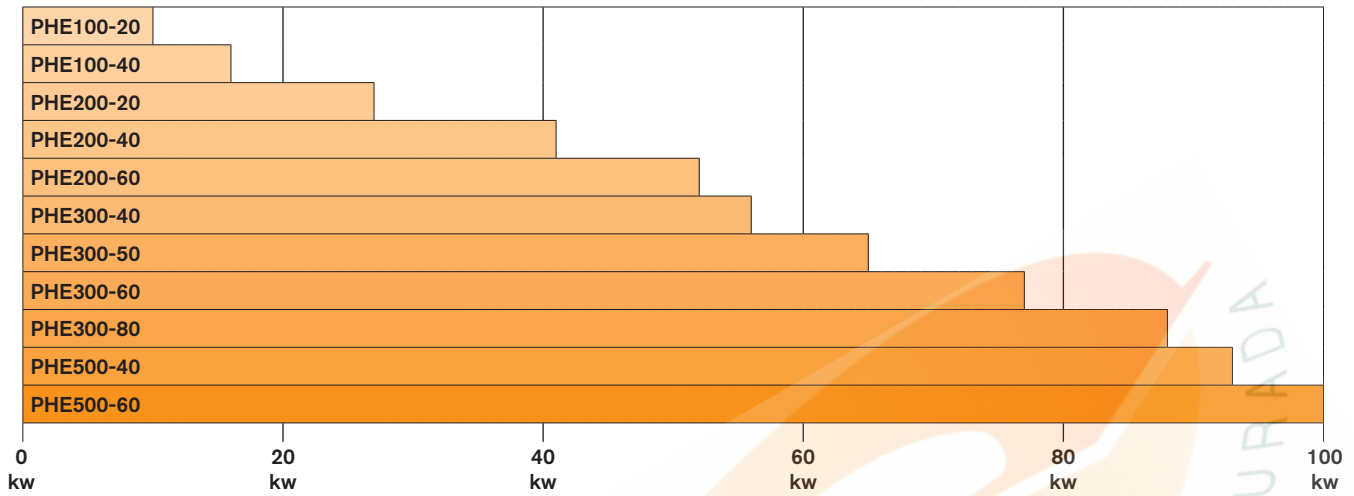

Type	Oil temperature switched on [°C]	Water temperature switched on [°C]	Oil flow [l/min]	Water flow [l/min]	Max. volume flow [l/min]
PHE100-20			60	30	66
PHE100-40			70	40	80
PHE200-20			120	60	
PHE200-40			160	80	
PHE200-60			180	90	
PHE300-40	60	20	120	60	200
PHE300-50			140	70	
PHE300-60			160	80	
PHE300-80			160	100	
PHE500-40			180	100	
PHE500-60			180	120	580

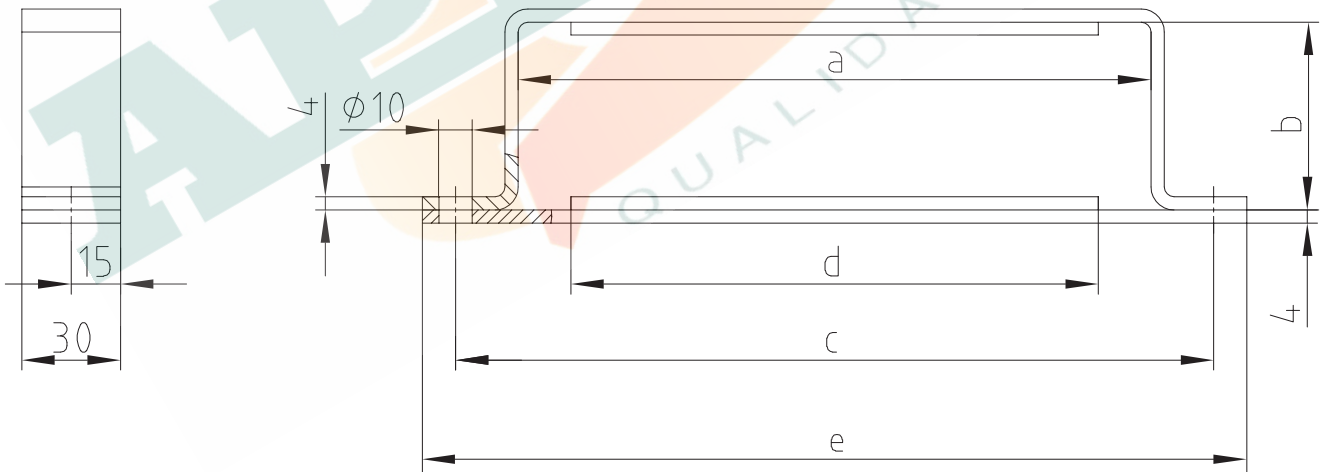

From size PHE 200 we recommend 2 retainers per cooler.

Fastening retainer					
Type	a	b	c	d	e
BH100-20	80	56	114	75	134
BH100-20HP	92	65	126	85	146
BH100-40HP	92	113	126	85	146
BH200/300-20	120	59	150	115	170
BH200/300-40	125	100	155	120	175
BH200/300-50	120	132	150	115	170
BH200/300-60	125	148	155	120	175
BH200/300-80	125	193	155	120	175
BH500-40		107			
BH500-60	200	155	235	193	260

Oil/water cooler TAK/TP

Cooling systems

Cooling of lubricating oil, heat recovery

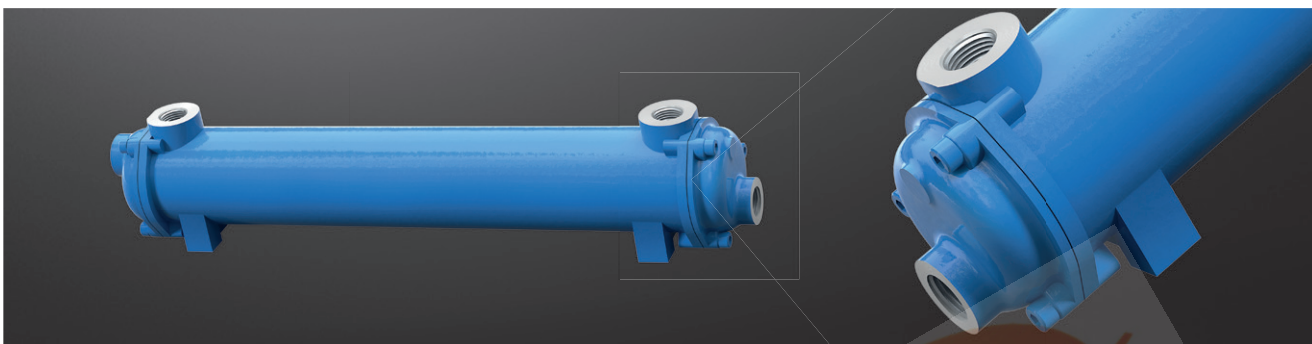

The TAK/TP cooler ranges were originally designed for hydraulic systems, but based on their design they are equally suitable for cooling lubricating oils, heat recovery, etc.

The tube bundle is designed in that it may expand to both sides, consequently minimizing thermal stresses.

The unique tube-to-tube plate joint ensures high reliability.

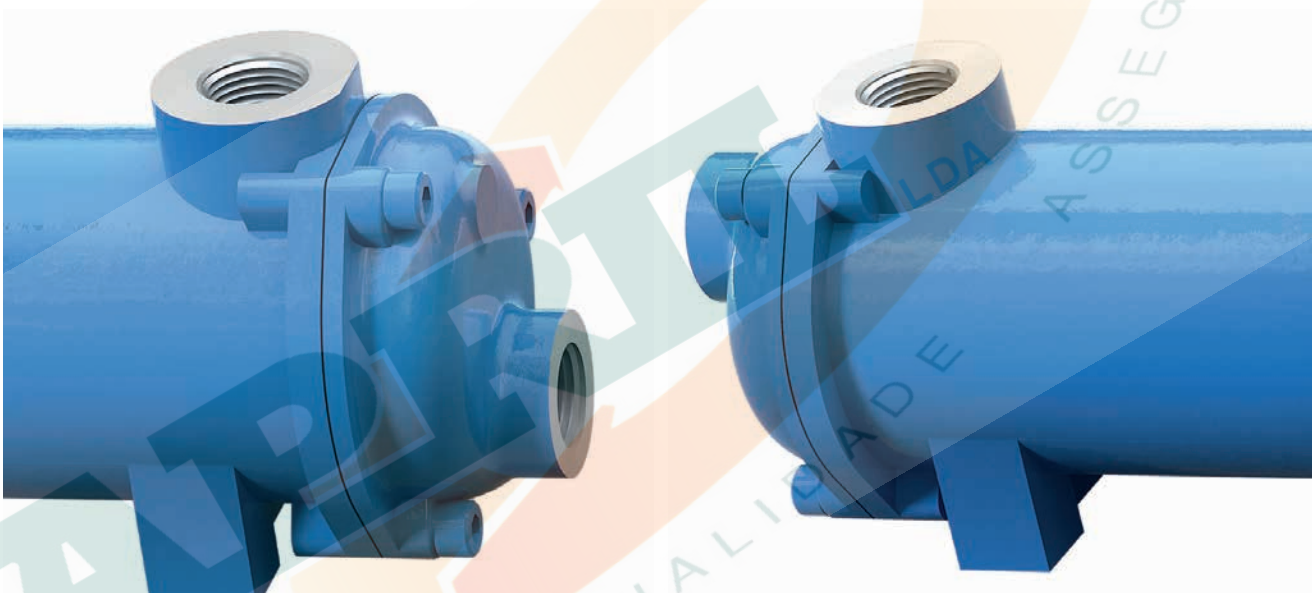

Materials used:

These coolers are available in both industrial and marine versions. (Tube bundles made of stainless steel on request)

Industrial version (standard)	
Tubes	Brass (EN CW614N)
Tube retainer	Brass
Housing	Aluminium
Headers	Brass (EN CW614N)
Gaskets	Nitrile

Marine version	
Tubes	90/10 copper/nickel

Oil/water cooler TAK/TP

Cooling systems

Cooling capacities, diagramme of performance, diagramme of pressure loss

Tubular heat cooler							
Coolers	Cooling capacity [kW]	Volume flow of oil [l/min]	Volume flow of water [l/min]	Pressure loss of oil [bar]	Pressure loss of water [bar]	Surface [m ²]	Maximum volume flow of water/sea water [l/min]
TAK/TP-A1	3	30	15	0.1	0.02	0.13	
TAK/TP-A2	6	46	23	0.19	0.05	0.22	
TAK/TP-A3	9	56	28	0.36	0.09	0.32	50/35
TAK/TP-A4	13	64	32	0.6	0.13	0.46	
TAK/TP-A5	16	56	28	0.56	0.12	0.68	
TAK/TP-B1	8	66	33	0.16	0.02	0.33	
TAK/TP-B2	12	80	40	0.32	0.03	0.48	
TAK/TP-B3	18	104	52	0.96	0.07	0.66	80/50
TAK/TP-B4	25	106	53	1	0.11	0.9	
TAK/TP-B5	29	98	49	1.04	0.14	1.16	
TAK/TP-C1	16	100	50	0.28	0.04	0.64	
TAK/TP-C2	26	120	60	0.55	0.07	0.9	
TAK/TP-C3	36	140	70	0.74	0.13	1.23	140/90
TAK/TP-C4	48	160	80	1.06	0.17	1.6	
TAK/TP-C5	56	140	70	0.95	0.16	2.07	
TAK/TP-C6	70	160	80	0.84	0.26	3.02	
TAK/TP-D1	40	180	90	0.4	0.07	1.58	
TAK/TP-D2	52	200	100	0.55	0.09	2.14	
TAK/TP-D3	66	220	110	0.62	0.12	2.79	190/110
TAK/TP-D4	84	240	120	0.8	0.16	3.57	
TAK/TP-D5	108	260	130	1	0.19	4.48	
TAK/TP-D6	120	240	120	0.96	0.21	5.38	
TAK/TP-E1	76	320	160	0.44	0.09	3.27	
TAK/TP-E2	106	360	180	0.64	0.13	4.24	
TAK/TP-E3	134	400	200	0.9	0.2	5.45	340/215
TAK/TP-E4	175	420	210	1.1	0.25	6.82	
TAK/TP-E5	205	400	200	1.15	0.28	8.22	
TAK/TP-E6	240	360	180	1.1	0.28	10.27	
TAK/TP-F1	133	720	360	0.36	0.09	7.2	
TAK/TP-F2	180	780	390	0.5	0.13	9.14	
TAK/TP-F3	250	840	420	0.62	0.17	11.81	800/500
TAK/TP-F4	325	900	450	0.76	0.25	14.6	
TAK/TP-F5	410	960	480	1	0.32	17.3	
TAK/TP-F6	500	900	450	1.16	0.52	21.54	

The table shows the performance assigned to the cooler with usual process data:

Oil outlet temperature: 50 °C; water inlet temperature: 25 °C, oil viscosity: 38 Cst and 50 °C. Any change of the parameters selected may result in a different selection of oil cooler.

Oil/water cooler TAK/TP

Cooling systems

Series A-C

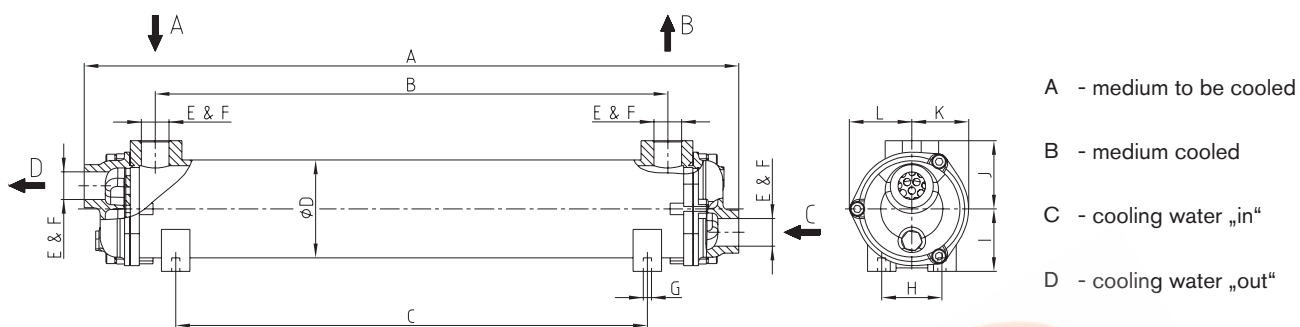

TAK/TP Series A-C												
Coolers	A	B	C	D	E & F	G	H	I	J	K	L	Weight
TAK/TP-A1	195	72	38									3
TAK/TP-A2	263	138	103									3.5
TAK/TP-A3	349	225	189									4
TAK/TP-A4	448	326	288	Ø86	G 3/4"	4xM8	53	55	60	50	55	4.7
TAK/TP-A5	576	450	415									5.5
TAK/TP-A6	731	603	557									10
TAK/TP-B1	273	123	109									5
TAK/TP-B2	355	205	191									6
TAK/TP-B3	452	302	289	Ø108	G 1"	4xM8	77	65	70	60	55	7
TAK/TP-B4	587	437	425									8.2
TAK/TP-B5	730	580	566									10
TAK/TP-C1	372	182	93									9
TAK/TP-C2	472	287	193									10
TAK/TP-C3	600	415	320									12.5
TAK/TP-C4	744	557	465	Ø130	G 1 1/4"	4xM10	78	75	80	70	80	14.5
TAK/TP-C5	922	737	643									17.5
TAK/TP-C6	1332	1146	1055									30

Max. perm. oil temperature 120 °C. Max. oil pressure 14 bars. Max. water pressure 10 bars.

Ordering example:

TAK/TP	A	1	M
Type	Series	Size	Seawater version ¹⁾

¹⁾ Code letter can be omitted with industrial design.

Oil/water cooler TAK/TP

Cooling systems

Series D-F

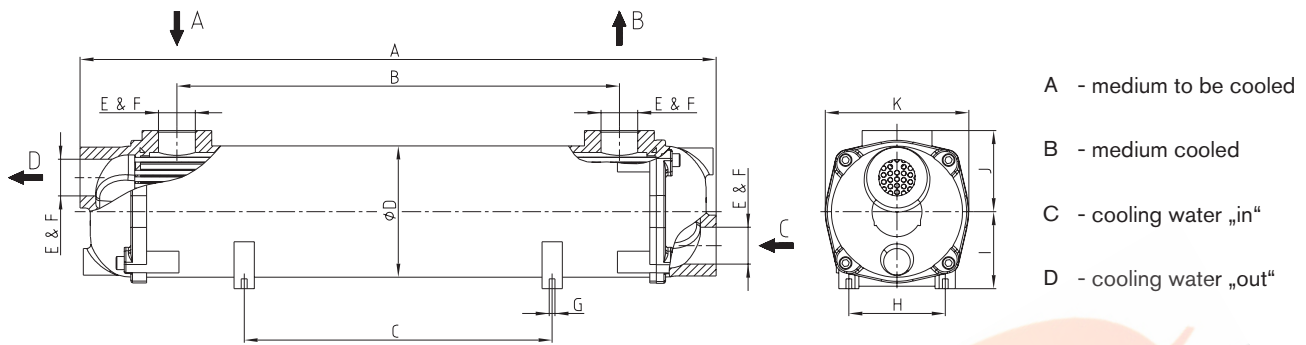

TAK/TP Series D-F												
Coolers	A	B	C	D	E & F	G	H	I	J	K	L	Weight
TAK/TP-D1	505	270	109									20
TAK/TP-D2	634	402	238									24
TAK/TP-D3	780	546	384									27
TAK/TP-D4	954	722	558	Ø162	G 1 1/2"	4xM10	119	95	100	177	-	32
TAK/TP-D5	1,160	928	764									38
TAK/TP-D6	1,364	1,132	968									45
TAK/TP-E1	675	372	239									33
TAK/TP-E2	816	513	380									39
TAK/TP-E3	998	696	560	Ø198	G 2"	4xM12	120	110	120	206	-	45
TAK/TP-E4	1,204	901	766									54
TAK/TP-E5	1,408	1,102	968									64
TAK/TP-E6	1,712	1,406	1,272									74
TAK/TP-F1	754	330	236									47
TAK/TP-F2	900	476	382									57
TAK/TP-F3	1,077	654	560									68
TAK/TP-F4	1,280	856	762	Ø278	G 3"	4xM16	180	155	170	288	-	79
TAK/TP-F5	1,484	1,060	966									91
TAK/TP-F6	1,790	1,364	1,270									105

Max. perm. oil temperature 120 °C. Max. oil pressure 14 bars. Max. water pressure 10 bars.

Ordering example:

TAK/TP	D	1	M
Type	Series	Size	Seawater version ¹⁾

¹⁾ Code letter can be omitted with industrial design.

Oil/water cooler TAK/TP

Cooling systems

Performance diagrammes

Performance diagramme of A series

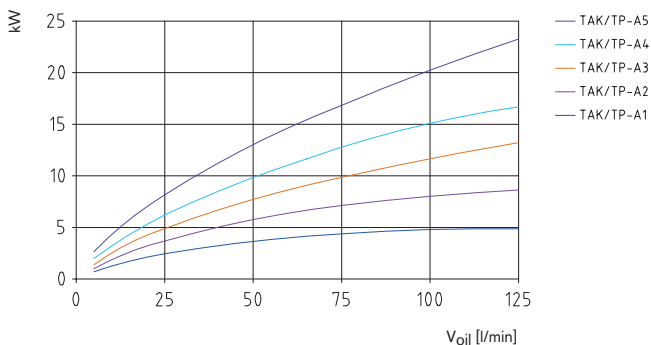

Performance diagramme of B series

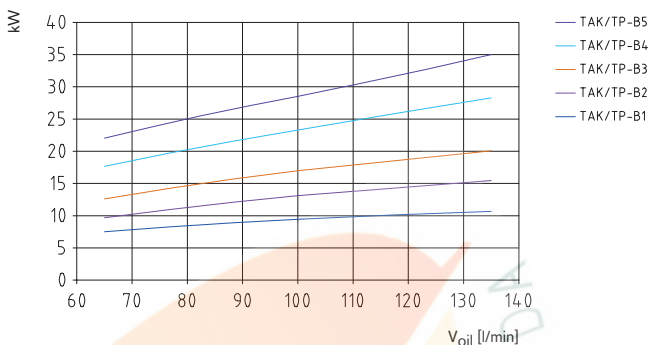

Performance diagramme of C series

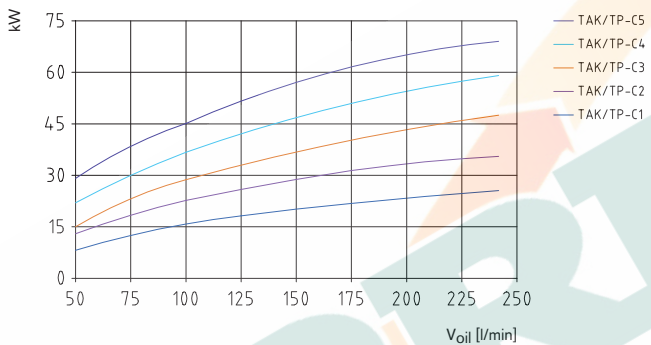

Performance diagramme of D series

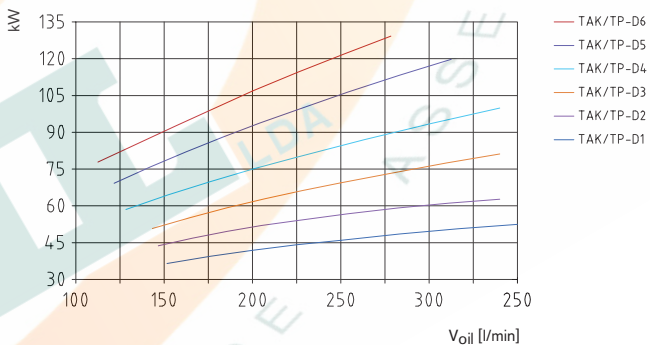

Performance diagramme of E series

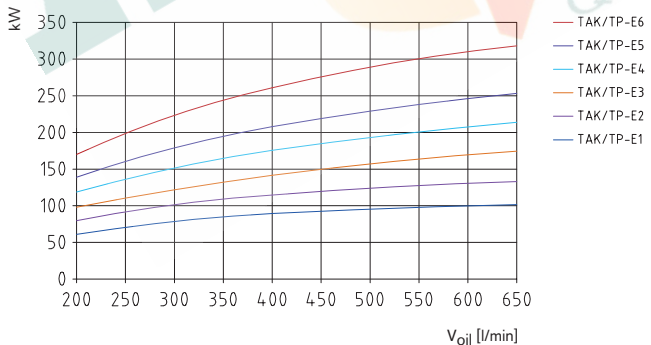

Performance diagramme of F series

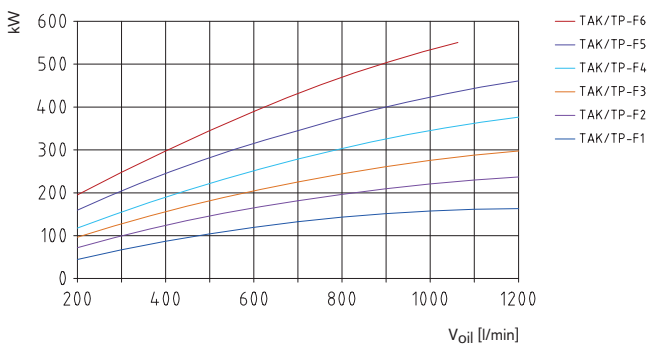

Notes



Summary of literature

No matter if a perfect drive, a brake that takes effect, space-saving cooling or accurate hydraulics is required, if on land, by sea or at an airy height - KTR's product portfolio is just as manifold as its applications. The following catalogues and leaflets provide an overview. Available at www.ktr.com

Product catalogues

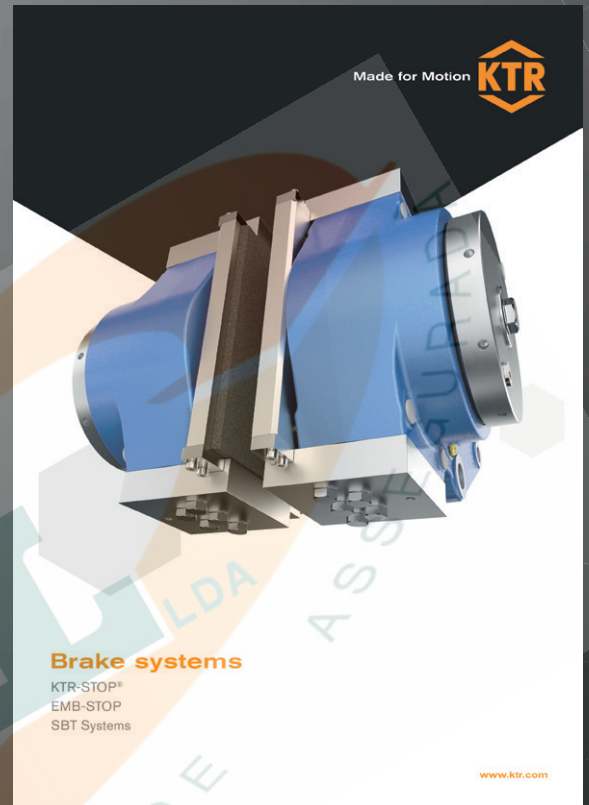
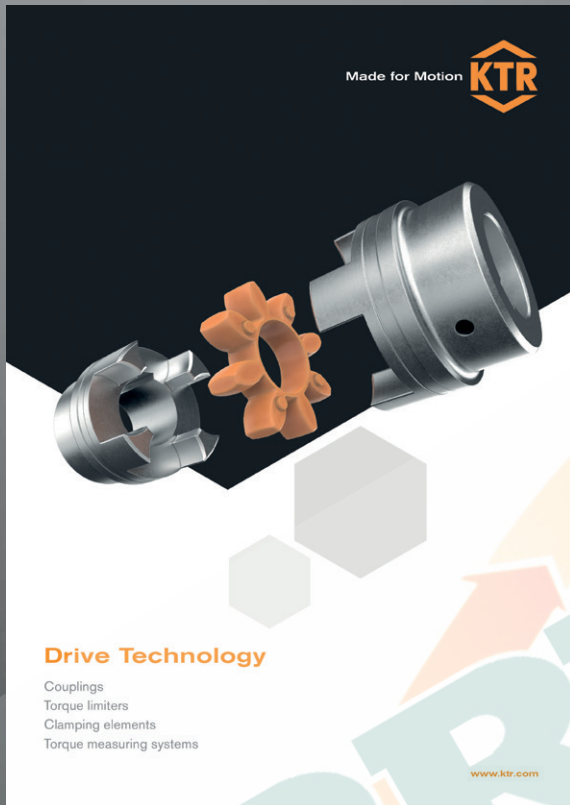

ATEX leaflet



Company leaflet



Made for Motion **KTR**

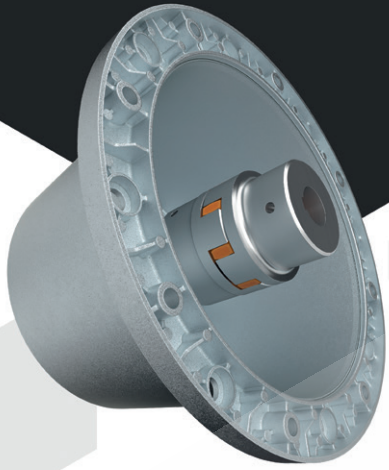

Hydraulic components

- Bellhousings
- Damping elements
- Cooling systems
- Oil tanks

www.ktr.com

Made for Motion **KTR**



Cooling systems

- For mobile machines and stationary hydraulics
- Customised solutions or standard design

www.ktr.com

KTR Germany:

Headquarters:

KTR Systems GmbH

Carl-Zeiss-Straße 25
D-48432 Rheine

Phone: +49 5971 798-0
Fax: +49 5971 798-698 or 798-450
E-mail: mail@ktr.com
Internet: www.ktr.com

KTR Brake Systems GmbH

Competence Center for Brake Systems
Zur Brinke 14

D-33758 Schloß Holte-Stukenbrock
Phone: +49 5207 99161-0
Mobile: +49 175 2650033

Leiter Vertrieb Bremsen Wind

Lino Gioroglou
Zur Brinke 14

D-33758 Schloß Holte-Stukenbrock
Phone: +49 5207 99161-72
Mobile: +49 16090 589741
E-mail: l.gioroglou@ktr.com

Leiter Vertrieb Bremsen Industrie

Thomas Wienkotte, Dipl.-Ing. (FH)
Am Rott 18

D-50171 Kerpen
Phone: +49 2237 971796
Mobile: +49 172 5859448
E-mail: t.wienkotte@ktr.com

Außendienst Norddeutschland für Hydraulik-Komponenten

Gunnar Ehlers
Finkenstieg 4b
21629 Neu Wulmstorf

Mobile: +49 174 3301536
E-mail: g.ehlers@ktr.com

Außendienst Bayern, Baden-Württemberg und Österreich für Hydraulik-Komponenten

Klaus-Peter Sprödhuber
Blumenstraße 6
95499 Harsdorf

Phone: +49 9203 9739450
Mobile: +49 172 1096496
E-mail: k.sproedhuber@ktr.com

Schleswig-Holstein, Nord-Niedersachsen, Hamburg, Bremen

Martin Lau, Maschinenbautechniker
KTR Ingenieurbüro Hamburg
Geschwister-Scholl-Allee 44
25524 Itzehoe

Phone: +49 4821 4050812
Mobile: +49 172 5310014
E-mail: m.lau@ktr.com

NRW: Großraum Düsseldorf, Köln, Aachen

John Wein,

B. Sc. Wirtschaftsingenieurwesen
Carl-Zeiss-Straße 25
48432 Rheine

Phone: +49 5971 798 7437
Mobile: +49 151 62489605
E-mail: j.wein@ktr.com

Emsland, Mitte- und Süd-Niedersachsen, Ostwestfalen

Rainer Lüttmann

KTR Systems GmbH
Carl-Zeiss-Straße 25
48432 Rheine

Phone: +49 5971 798-340
Mobile: +49 172 5322164
E-mail: r.luettmann@ktr.com

NRW: Süd, Westfalen und Nordhessen

René Szabó,

Techniker u. techn. Betriebswirt (IHK)
Waldstr. 67

57080 Siegen-Niederschelden
Phone: +49 5971 798 7777
Mobile: +49 175 81 64 844
E-mail: r.szabo@ktr.com

Hessen, Rheinland-Pfalz, Saarland

Martin Dietrich, Ingenieur Maschinenbau
KTR Ingenieurbüro Frankfurt
Schorbachstr. 9

35510 Butzbach
Phone: +49 6033 9248494
Mobile: +49 172 5329968
E-mail: m.dietrich@ktr.com

Berlin, Mecklenburg-Vorpommern Südost, Sachsen-Anhalt, Brandenburg

Thüringen Nord, Sachsen
Norman Schlag, Tech. BW (IHK)
KTR Ingenieurbüro Leipzig
Hauptstraße 101

04416 Markkleeberg
Phone: +49 341 35416467
Mobile: +49 173 4716266
E-mail: n.schlag@ktr.com

Baden-Württemberg Nord

Eberhard Maier, Dipl.-Ing. (FH)
Hortensienweg 1
70374 Stuttgart, Sommerain

Phone: +49 71 16 5842957
Mobile: +49 172 5355056
E-mail: e.maier@ktr.com

Baden-Württemberg Süd

Jochen Glöckler, Maschinenbautechniker
KTR Ingenieurbüro Balingen

Höhlstraße 44
72336 Balingen

Phone: +49 7433 91381
Mobile: +49 172 5310049
E-mail: j.gloeckler@ktr.com

Bayern-Nord, Thüringen Süd

Alexander Ennulat, Dipl.-Ing.
KTR Ingenieurbüro Römerstein
Grabenstetter Str. 28
72587 Römerstein

Phone: +49 7382 9369226
Mobile: +49 162 4160354
E-mail: a.ennulat@ktr.com

Bayern-Süd, Baden-Württemberg Ost

Peter Benkard, Dipl.-Ing. (FH)
KTR Ingenieurbüro Adelsried
Am Mittelfeld 13
86477 Adelsried

Phone: +49 8293 9605-04
Mobile: +49 172 5313059
E-mail: p.benkard@ktr.com

For all representatives and sales partners refer to www.ktr.com.

KTR worldwide:

Algeria

KTR Algérie
Phone: +213 661 92 24 00
Phone: +33 4 78 64 54 66
E-mail: ktr-dz@ktr.com

Brazil

KTR do Brasil Ltda.
Rua Jandaia do Sul 471 -
Bairro Emiliano Perneta
Pinhais - PR - Cep: 83324-440
Phone: +55 41 36 69 57 13
E-mail: ktr-br@ktr.com

Chile

KTR Systems Chile SpA
Calle Bucarest 17
Oficina 33 Providencia
Santiago de Chile
Phone: +56 23 22 46 674
Mobile: +56 9 44 75 57 02
E-mail: ktr-cl@ktr.com

China

KTR Power Transmission Technology
(Shanghai) Co. Ltd.
Building 1005, ZOBON Business Park
999 Wangqiao Road
Pudong
Shanghai 201201
Phone: +86 21 58 38 18 00
Fax: +86 21 58 38 19 00
E-mail: ktr-cn@ktr.com

Czech Republic

KTR CR, spol. s r.o.
Brněnská 559
569 43 Jevíčko
Czech Republic
Phone: +420 461 325 014
E-mail: ktr-cz@ktr.com

Denmark

KTR Systems Danmark ApS
Vejlsøvej 51, Bygning N
8600 Silkeborg
Phone: +45 39 39 10 50
E-mail: ktr-dk@ktr.com

Finland

KTR Finland OY
Tiistinnityntie 4
FIN-02230 Espoo
Phone: +358 2 07 41 46 10
E-mail: ktr-fi@ktr.com

France

KTR France SAS
5 Chemin de la Brocardière
CS 71359
F-69573 DARDILLY CEDEX
Phone: +33 4 78 64 54 66
Fax: +33 4 78 64 54 31
E-mail: ktr-fr@ktr.com

India

KTR Couplings (India) Pvt. Ltd.,
T - 36 / 37 / 38 / 39, MIDC Bhosari,
Pune Maharashtra 411026
Phone: +91 20 27 12 73 24 / 25
Fax: +91 20 27 12 73 23
E-mail: ktr-in@ktr.com;
india.sales@ktr.com

Italy

KTR Systems GmbH
Sede Secondaria Italia
Via Giacomo Brodolini, 8
I - 40133 Bologna (BO)
Phone: +39 051 613 32 32
Fax: +39 051 298 55 77
E-mail: ktr-it@ktr.com

Japan

KTR Japan Co., Ltd.
c/o The Sumitomo Warehouse Co., Ltd.
Kobe Branch, Chuo Logistics Center L-6
7-14 Minatojima, Chuo-ku, Kobe City,
Hyogo 650-0045 Japan
Phone: +81 78 381 84 01
Fax: +81 78 945 85 60
E-mail: ktr-jp@ktr.com

Korea

KTR Korea Ltd.
#604, Songwon bldg., 89-10,
Galmaejungang-ro, Guri-si,
Gyeonggi-do, 11901 Korea
Phone: +82 3 15 69 45 10
Fax: +82 3 15 69 45 25
E-mail: ktr-kr@ktr.com

Netherlands

KTR Benelux B. V.
Postbus 87
Oosterveldsingel 3
NL-7558 PJ Hengelo (O)
Phone: +31 74 2553680
E-mail: ktr-nl@ktr.com

Norway

KTR Systems Norge AS
Lahaugmoveien 81
N-2013 Skjetten
Phone: +47 64 83 54 90
E-mail: ktr-no@ktr.com

Poland

KTR Polska Sp. z o.o.
ul. Czerwone Maki 65
PL-30-392 Kraków
Phone: +48 12 267 28 83
E-mail: ktr-pl@ktr.com

Singapore

KTR Systems Singapore Pte. Ltd.
2 Venture Drive
#13-02 Vision Exchange
Singapore 608526
Phone: +65 69 04 12 32
Mobile: +65 96 33 66 92
E-mail: a.low@ktr.com

South Africa

KTR Couplings SA (Pty) Ltd.
28 Spartan Road, Kempton Park,
Spartan Ext. 21
Phone: +27 11 281 3801
Fax: +27 11 281 3812
E-mail: ktr-za@ktr.com

Spain

KTR Systems GmbH
Estartetxe, nº 5-Oficina 322
E-48940 Leioa (Vizcaya)
Phone: +34 9 44 80 39 09
Fax: +34 9 44 31 68 07
E-mail: ktr-es@ktr.com

Sweden

KTR Sverige AB
Box 7010
S-187 11 Täby
Phone: +46 86 25 02 90
E-mail: info.se@ktr.com

Switzerland

KTR Systems Schweiz AG
Bahenstr. 60
CH-8105 Regensdorf
Phone: +41 4 33 11 15 48
Fax: +41 4 33 11 15 56
E-mail: ktr-ch@ktr.com

Taiwan

KTR Taiwan Ltd.
No. 30-1, 36 Rd., Taichung Industry Zone,
Xitun Dist., Taichung City 40768,
Taiwan (R.O.C)
Phone: +886 4 23 59 32 78
Fax: +886 4 23 59 75 78
E-mail: ktr-tw@ktr.com

Turkey

KTR Turkey
Güç Aktarma Sistemleri San. ve Tic. Ltd.
Sti. Kayışdağı Cad. No: 117/2
34758 Ataşehir -Istanbul
Phone: +90 216 574 37 80
Fax: +90 216 574 34 45
E-mail: ktr-tr@ktr.com

United Kingdom

KTR U.K. Ltd.
Robert House
Unit 7, Acorn Business Park
Woodseats Close
Sheffield
United Kingdom, S8 0TB
Phone: +44 11 42 58 77 57
Fax: +44 11 42 58 77 40
E-mail: ktr-uk@ktr.com

USA

KTR Corporation
122 Anchor Road
Michigan City, Indiana 46360
Phone: +1 2 19 8 72 91 00
Fax: +1 2 19 8 72 91 50
E-mail: ktr-us@ktr.com



Headquarters

KTR Systems GmbH

Carl-Zeiss-Straße 25

D-48432 Rheine

Phone: +49 5971 798-0

Fax: +49 5971 798-698 or 798-450

E-mail: mail@ktr.com

Internet: www.ktr.com

Made for Motion

